

FIELD CUT PANEL RIBS  
AND BEND PAN OVER  
TO FORM OPEN HEM

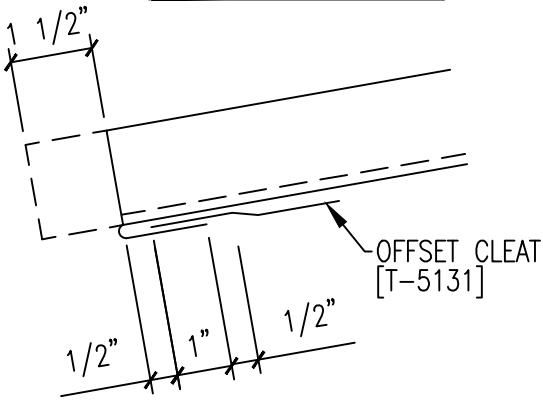

FILL END OF RIB W/  
URETHANE SEALANT

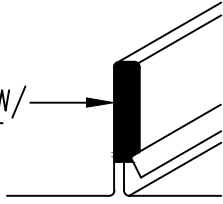

12

