

**FINISHING OFF MODULE**

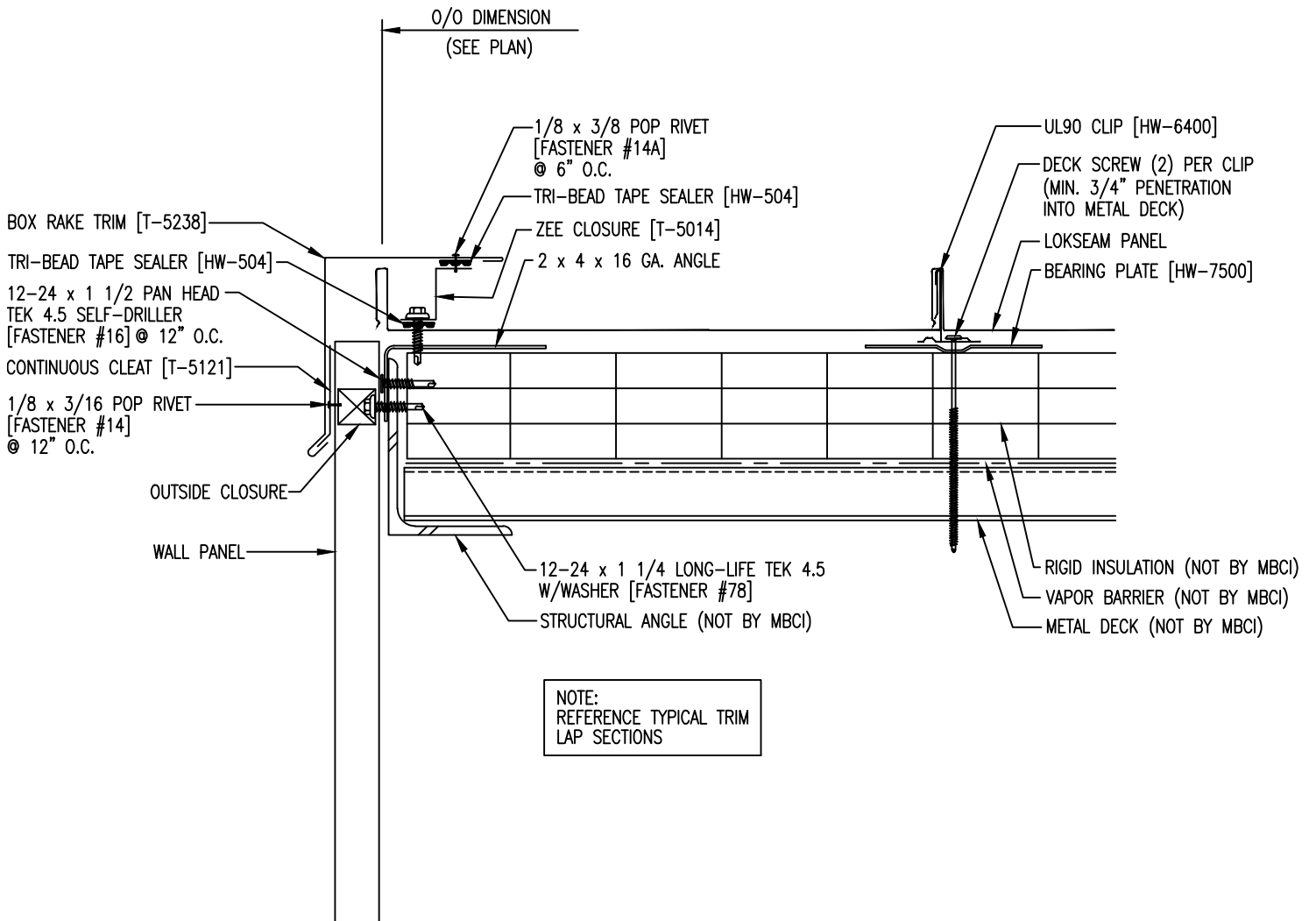

NOTE:  
REFERENCE TYPICAL TRIM  
LAP SECTIONS