

CRAFTSMAN SB BATTEN CAP [FL-566]
 FILL END W/ URETHANE SEALANT

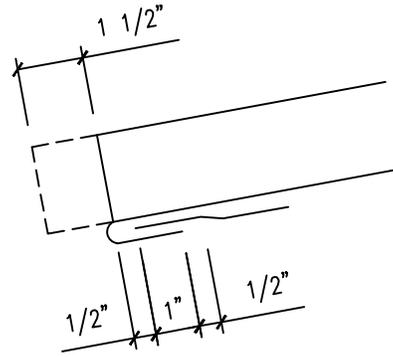
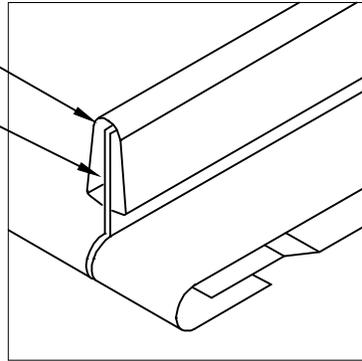

FIELD NOTCH PANEL
 LEGS AND BEND PAN
 TO FORM OPEN HEM

PANEL ENGAGEMENT DETAIL

12

