

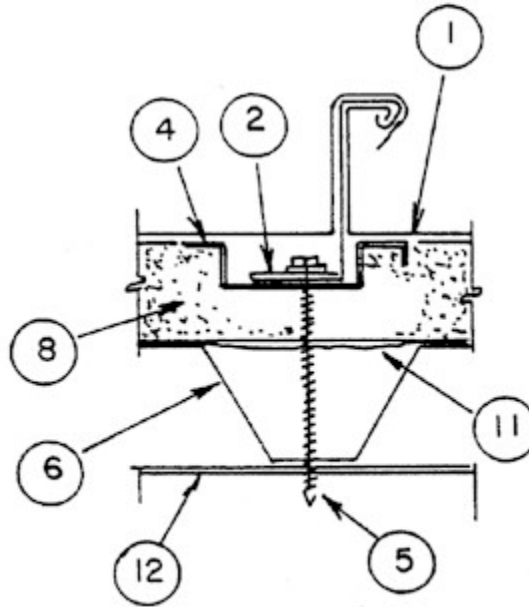

**Construction No. 238B**

Uplift - Class 90  
Fire Not Investigated

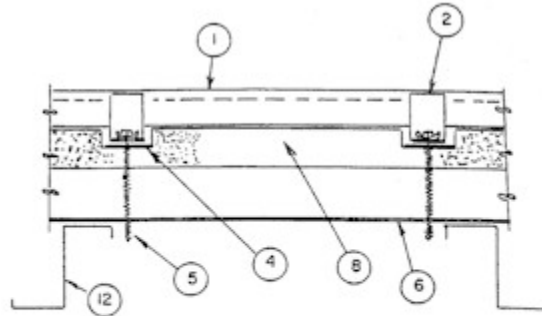

**1. Metal Roof Deck Panels\*** - No. 24 MSG min. coated steel. Max panel width 16 in. and rib height 2 in. Panels continuous over two or more spans. Endlap for "BattenLok" or "SuperLok" panels to be 6 in. and to include back up plate (Item 3). Endlap for "Master-Span" and "KA2000" panels to be 2 in. and to include back up plate (Item 3A). A bead of sealant may be used at panel ends and side joints. Side laps to be tightened and crimped with an electric crimping machine to an angle of 45 degree min. Crimping process to include the upper portion of panel clips (Items 2 or 2A).

- A&S BUILDING SYSTEMS, INC.-"BattenLok" or "SuperLok"
- MBCI-"BattenLok" or "SuperLok"
- MESCO METAL BUILDINGS-"BattenLok" or "SuperLok"

- NCI BUILDING SYSTEMS LP--"BattenLok" or "SuperLok"
- METAL SALES MFG. CORP - "Master-Span"
- KIRBY BUILDING SYSTEMS INC. - "KA2000"
- KNUDSON MFG. INC. - "Ultralok"

**1A. Metal Roof Deck Panels\*** - Panels may be physically curved at a radius of 110 ft. or greater.

- A&S BUILDING SYSTEMS, INC.-"BattenLok" or "SuperLok"
- MBCI-"BattenLok" or "SuperLok"
- MESCO METAL BUILDINGS-"BattenLok" or "SuperLok"
- NCI BUILDING SYSTEMS LP--"BattenLok" or "SuperLok"

**2. Roof Deck Fasteners\*** - Fixed Clip or Utility - One piece assembly fabricated from No. 22 MSG min. steel, 3in. wide. Floating Clip - two piece assembly with a base fabricated from No. 16 MSG min steel, and a top fabricated from No. 22 MSG steel, 4-1/4 in. wide. Clip spacing to be 48 in. O.C. max. Sealant may be used in the top of the clips.

- NCI BUILDING SYSTEMS LP-"BattenLok High or Low, Fixed or Floating Clip"; "BattenLok Utility Clip" - "SuperLok High or Low, Fixed or Floating Clip"; "SuperLok Utility Clip"

**2A. Roof Deck Fasteners\* (Panel Clips)** - Used with "Master-Span" panels, one piece or two piece assembly. One piece assembly fabricated from No. 23 MSG min. coated steel width 3 in., height 2-5/16 in. Base and tab of two piece assembly fabricated from No. 24 MSG min. coated steel. Maximum height of assembly 3-3/8 in. Clips spaced 30 in. O.C. max along length of panel ribs.

- METAL SALES MFG CORP - "Master-Span Fixed Clip" or "Master-Span Floating Clip"

**3. Endlap Back-Up Plate\*** (Not Shown) - No. 16 MSG min. coated steel, 15-1/2 in. wide with two 1 in. wide by 3/4 in. long tabs for sliding over end of panels.

**3A. Roof Deck Fasteners** - (Endlap back-up plate) - (Not Shown) - No. 16 MSG min. coated steel. Width 15-7/8 in., length 6-5/8 in. with a 1/2 in. deep vertical leg and a 1/2 in. wide horizontal leg and with 3 tabs, 3/4 in. wide and 3/4 in. long to be slipped over end of lower panel at end lap.

- METAL SALES MFG CORP - "Master-Span Compression Plate"

**4. Bearing Plate** - (Optional) - No. 16 MSG min. coated steel, 3-7/8 in. wide by 5 in. long or No. 18 MSG min. coated steel, 3-5/8 in. wide by 3 in. long. Used under panel clip (Item 2) over rigid insulation (Item 8).

**4A. Roof Deck Fasteners\*** - (Bearing Plate) - (Optional) - No. 18 MSG min. coated steel, 3 in. wide, 5 in. long with three 3/8 in. deep vertical legs. Used under panel clips (Item 2A) over rigid insulation. Three 5/16 in. diameter guide holes located in central area of plate.

- METAL SALES MFG CORP - "Master-Span Low Bearing Plate"

**4B. Roof Deck Fasteners\*** - (Bearing Plate) - (Not Shown) - No. 16 MSG min. coated steel, 15-7/8 in. wide, 5 in. long. Used under panel clips (Item 2) over rigid insulation. Two 5/16 in. elongated guide holes located at center of plate width and one at center.

- METAL SALES MFG CORP - "Master-Span Bearing Plate"

**5. Panel Fasteners - (Screws)** - Screws used to attach the panel clips (Items 2 or 2A) to liner panel (Item 6) to be No. 14 Truss Head with No. 3 Phillips drive. Length to be a min. of 1/2 in. longer than the combined thickness of the liner panel (Item 6), rigid insulation (Item 8), gypsum wallboard (Item 10) and plywood or oriented strand board (Item 10). Two screws per clip. Screws used to attach liner panel (Item 6) to purlins (Item 12) to be No. 12 x 1-1/4 in. self-drilling. Hex Head with 5/8 in. O.D. washer. Two screws to be used at each valley. Screws at liner panel side laps to be the same type as liner panel to purlin screws. Spacing to be 20 in. O.C.

Screws used at endlap to be one of the following: 14 x 1 in. Type AB, Hex Washer Head self-tapping, 14 x 1-1/4 in. Hex Washer Head, self-tapping; 14 x 1 in. Type AB Phillips Stainless Steel, Self-tapping. Five screws per panel in a 1,4,5,5,3 in. pattern.

**6. Metal Deck** - No. 22 MSG min. steel. Min. yield strength 30 KSI. Min. depth 1-1/2 in. Panel type to be A, B, F or N Deck. As an alternate metal deck, 22 MSG min steel, min yield strength 80 KSI, min depth 15/16 in. designated Type HD may be used; Liner panel to be fastened to supports with screws as indicated in Item 4 or with welds and weld washers of type indicated by manufacturer of liner panel. Welds to be located in each valley.

**7. Fastener Reinforcement - (Not Shown)** - Reinforcements used with the screws attaching the metal deck to the purlins. Thickness to be 0.125 in. with an area of approx. 2 sq/in.

**8. Foamed Plastic - (Rigid Insulation)** - (Optional) - Min. thickness 1 in. Any rigid type having a minimum compressive strength of 25 psi or minimum density of 2 pcf or see products Classified under TJBX. Supplied in 4 ft. wide sheets.

**9. Plywood or OSB** - (Optional) - (Not Shown) - Min. APA Rated plywood, nom 1/2 in. thick or oriented strand board (OSB), nom 7/16 in. thick, 4 x 8 ft. Sheets to be installed on top of Foamed Plastic (Item 8) in lieu of bearing plates (Items 4 or 4A).

**10. Wallboard, Gypsum** - (Optional) - (Not Shown) - Any 5/8 in. thick gypsum wallboard supplied in sheets 2 x 4 to 4 x 12 ft. Applied perpendicular to steel roof deck direction with adhesive. End joints to occur over crests of steel roof deck and be staggered 2 ft. in adjacent rows. As an alternate, any 1/2 in. thick gypsum board can be placed on top of the foamed plastic rigid insulation (Item 8). The total cumulative thickness of the rigid board (Item 8) and gypsum board may not exceed 4-1/2 in.

**11. Vapor Barrier** - (Optional) - Used between liner panel and foamed plastic. Min. 6 mil plastic sheeting.

**12. Supports - (Purlins)** - Purlins used for liner panels to be cold formed steel sections. As alternates: structural steel components (hot rolled beams, channels, etc.) may be used. Min. gauge and yield to depend on design considerations. Max spacing to depend on design considerations.

Refer to General Information, Roof Deck Construction, (Roofing Materials and Systems Directory) for Items Not Evaluated.

\*Bearing the UL Classification Marking