

HIGH EAVE SEALANT DETAIL

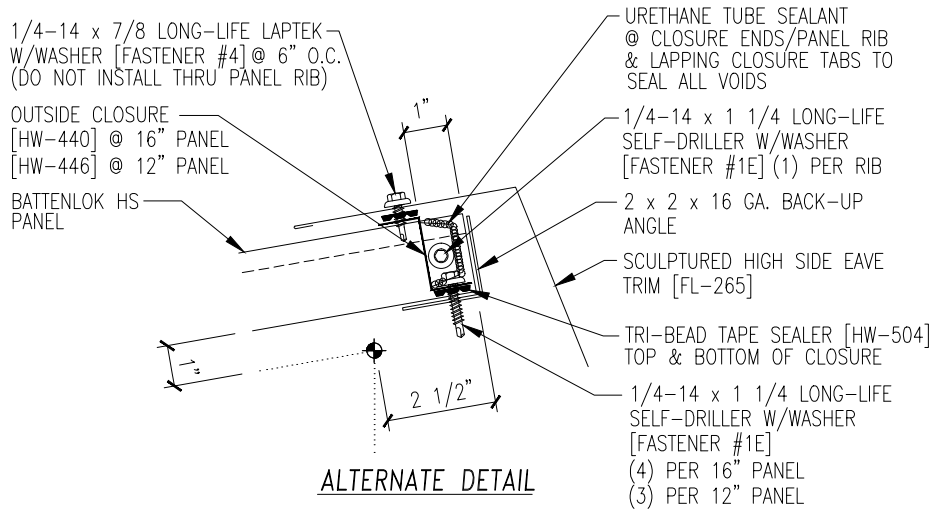

ALTERNATE DETAIL

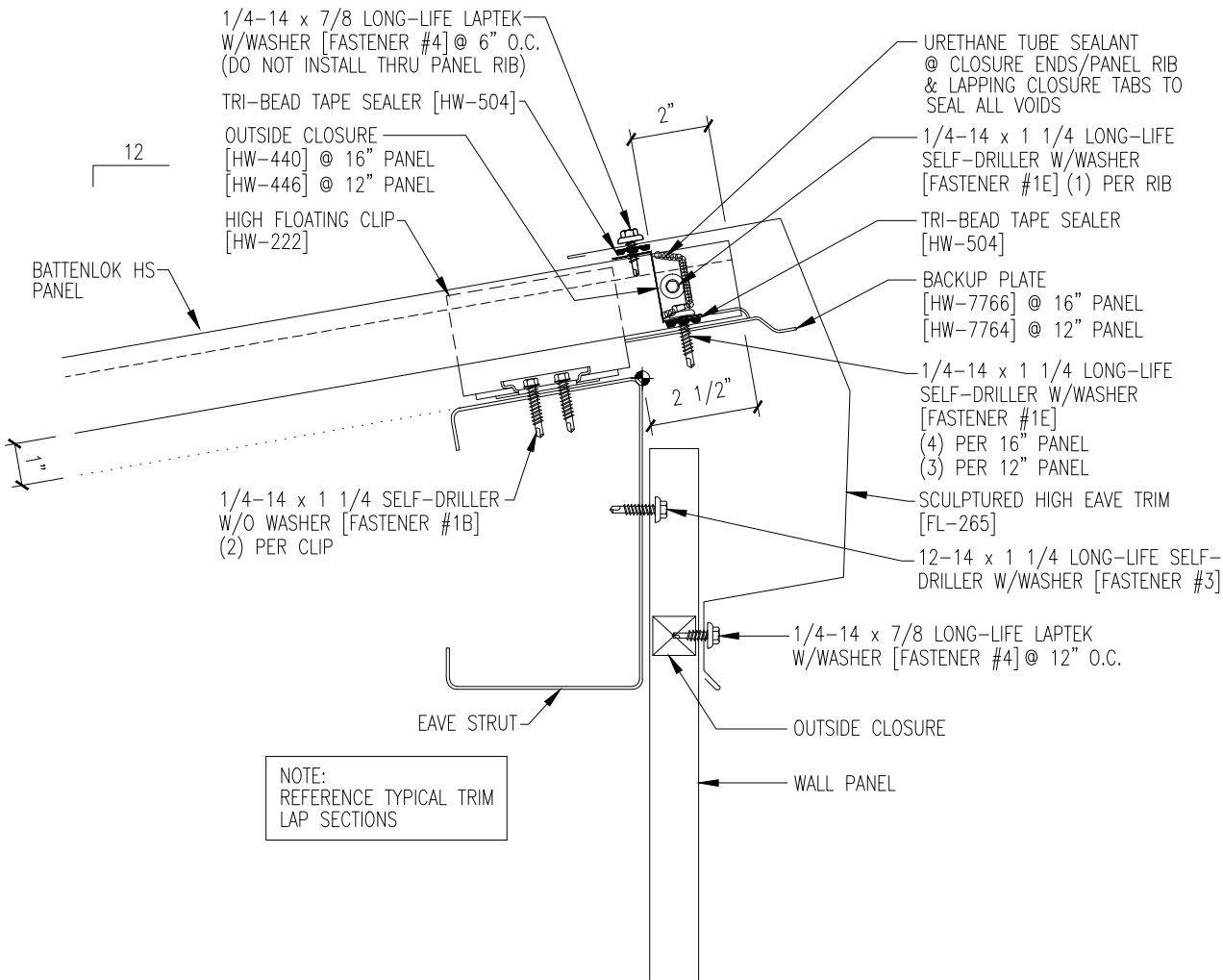

NOTE:
REFERENCE TYPICAL TRIM
LAP SECTIONS

O/O DIMENSION
(SEE PLAN)