

**GUTTER STRAP ATTACHMENT**

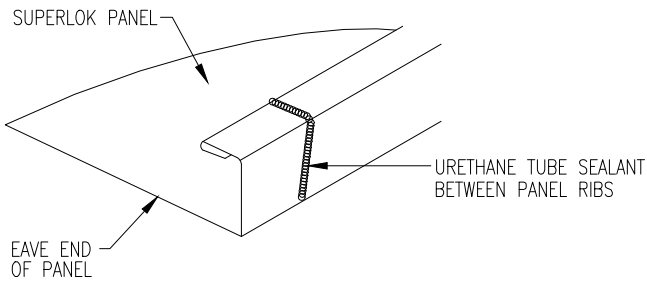

**EAVE SEALANT DETAIL**

URETHANE SEALANT MUST COME IN CONTACT WITH TAPE SEALER TO FORM A WEATHERTIGHT SEAL

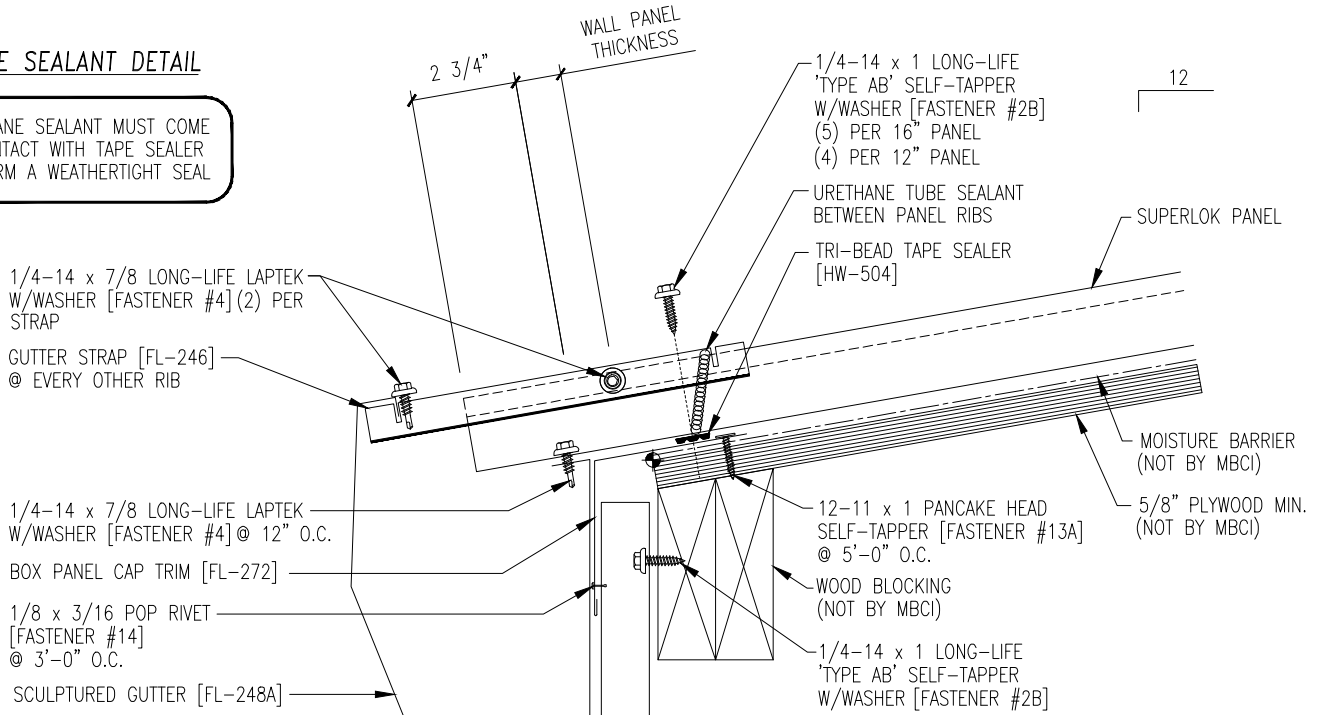
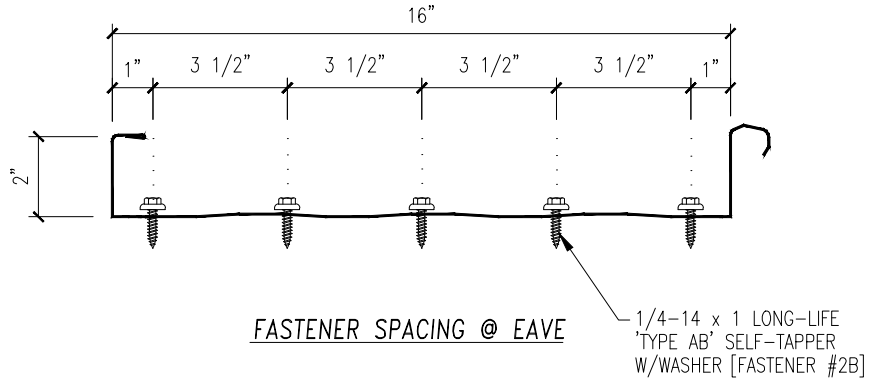
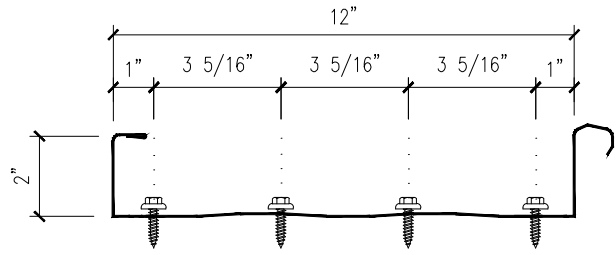

NOTE: REFERENCE TYPICAL TRIM LAP SECTIONS

O/O DIMENSION (SEE PLAN)