

BUTYL SEALANT MUST COME IN CONTACT WITH THE OFFSET CLEAT TO FORM A WEATHERTIGHT SEAL

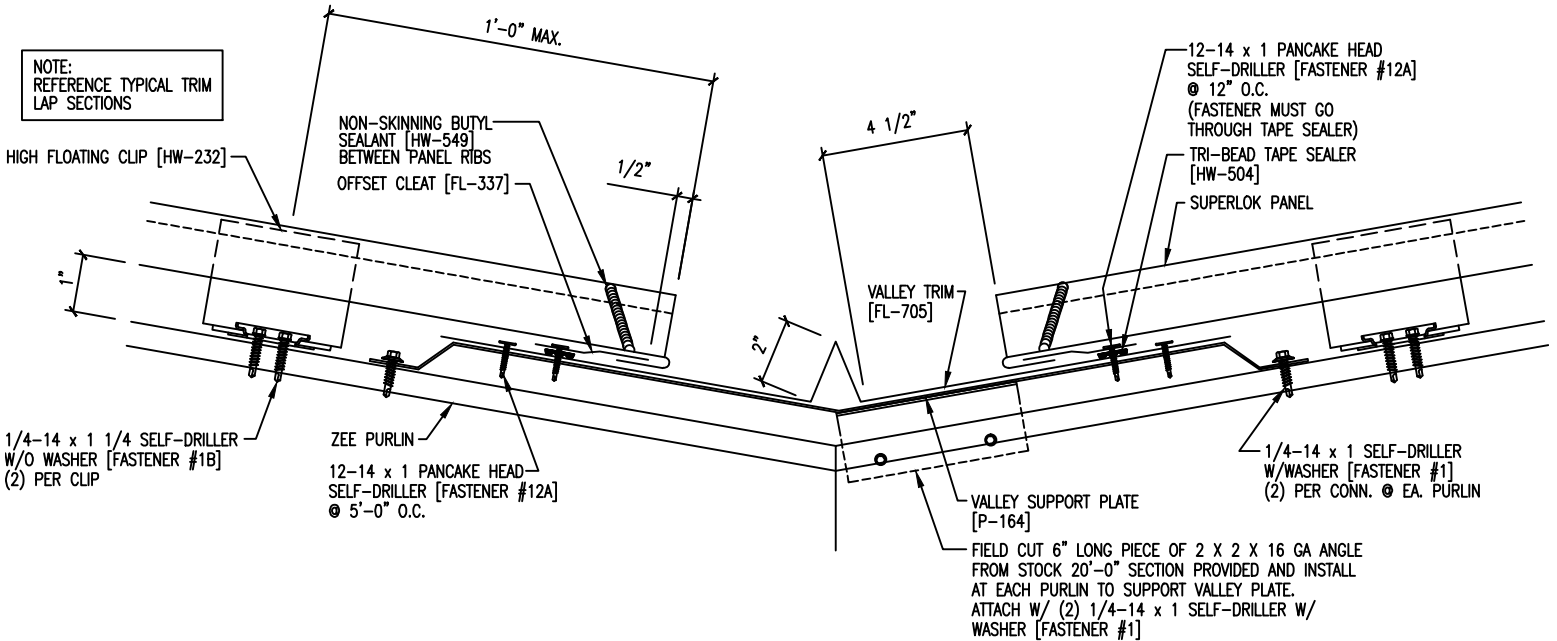

NOTE:  
DO NOT USE THIS DETAIL ON ROOF SLOPES LESS THAN 3:12 OR IN AREAS W/ SNOW LOADS 10 PSF OR GREATER