

O/O DIMENSION  
(SEE PLAN)

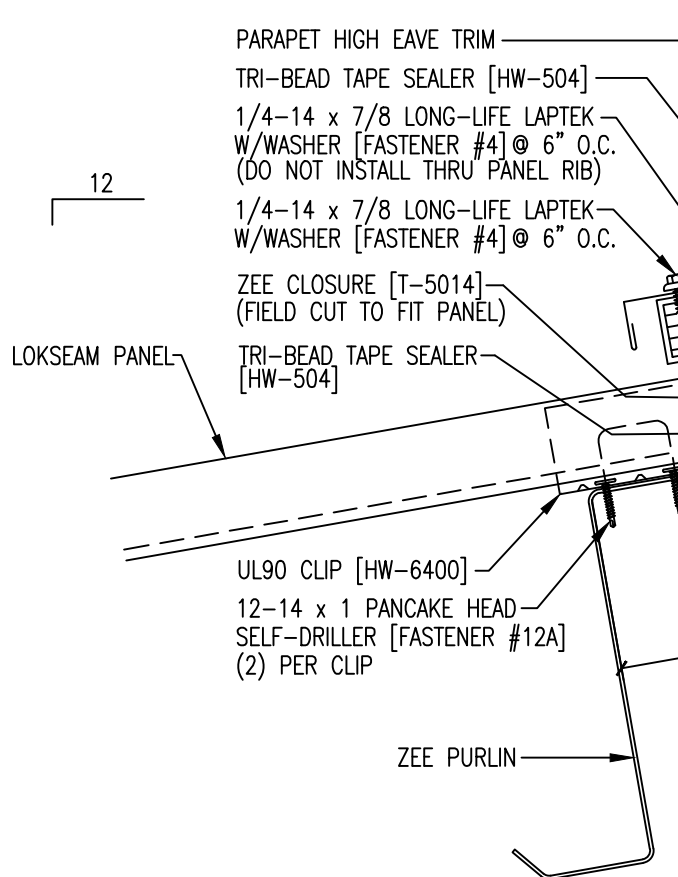

MASONRY WALL (NOT BY MBCI)

URETHANE TUBE SEALANT CONTINUOUS COUNTERFLASH [T-5225]

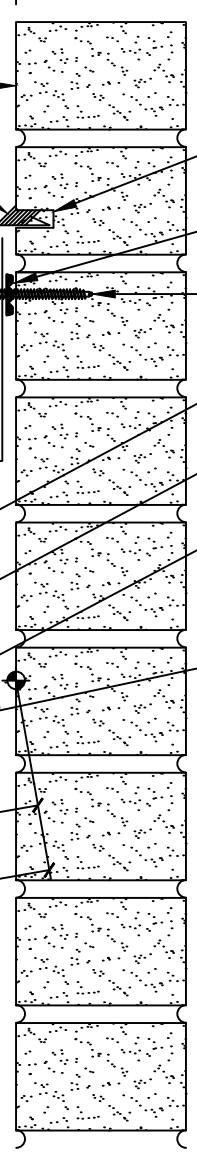

FIELD SAWCUT

TRI-BEAD TAPE SEALER [HW-504]

14-10 x 2 DECK SCREW [FASTENER #209] @ 24" O.C. (PRE-DRILL HOLE)

METAL VENT MATERIAL [HW-525]

URETHANE TUBE SEALANT @ CLOSURE ENDS

BACK-UP PLATE [HW-7762] 18" PANEL [HW-7766] 16" PANEL [HW-7764] 12" PANEL

1/4-14 x 1 1/4 LONG-LIFE SELF-DRILLER W/WASHER [FASTENER #1E] @ 6" O.C.

NOTE:  
REFERENCE TYPICAL TRIM  
LAP SECTIONS