

CRAFTSMAN SB BATTEN CAP [FL-566]
 FILL END W/ URETHANE SEALANT

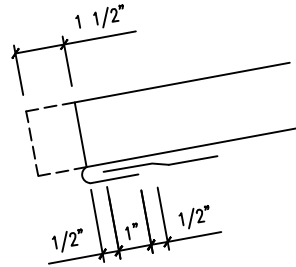

FIELD NOTCH PANEL LEGS AND BEND PAN TO FORM OPEN HEM

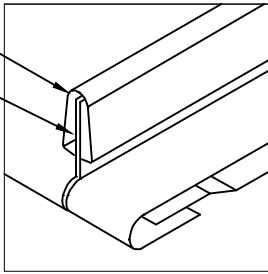
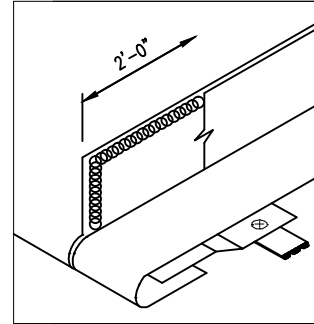

FIELD APPLY BEAD OF URETHANE SEALANT TO VERTICAL LEG OF PANEL BEFORE INSTALLING ADJACENT PANEL

PANEL ENGAGEMENT DETAIL

VALLEY SEALANT DETAIL

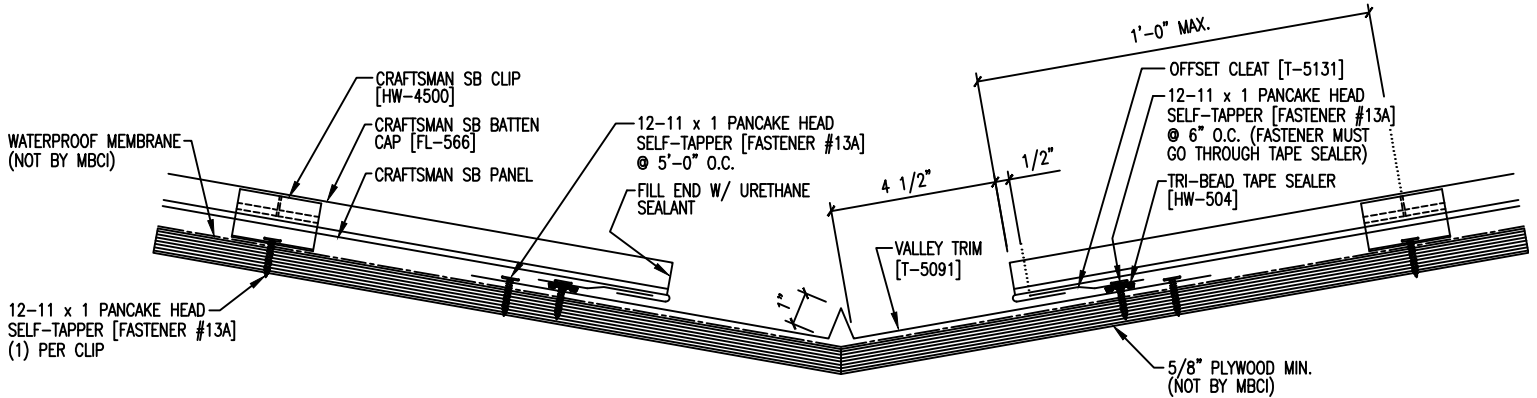

NOTE:
 REFERENCE TYPICAL TRIM LAP SECTIONS