

DETAIL "A"

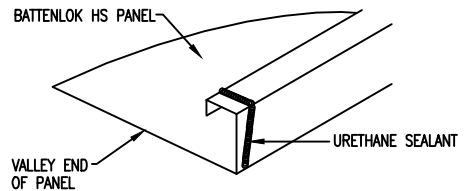

URETHANE SEALANT MUST COME IN CONTACT WITH TAPE SEALER TO FORM A WEATHERTIGHT SEAL

DETAIL A

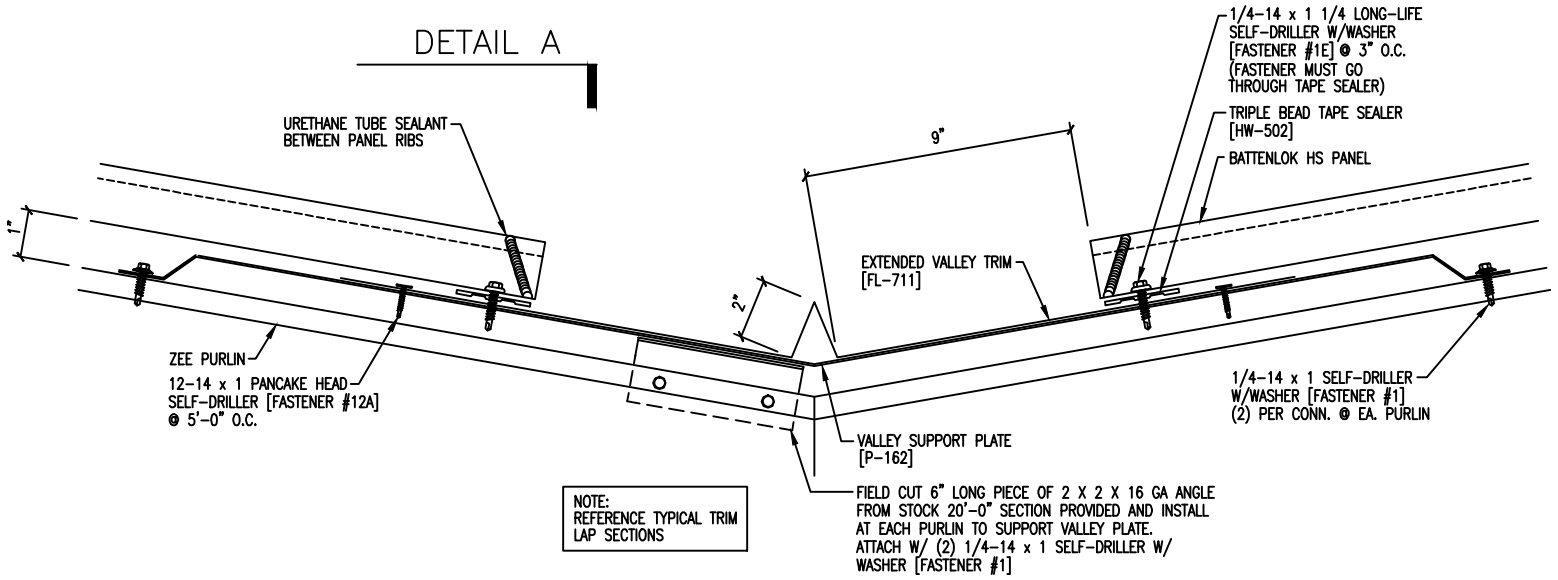

NOTE: REFERENCE TYPICAL TRIM LAP SECTIONS