

FIELD CUT PANEL RIBS  
AND BEND PAN OVER  
TO FORM OPEN HEM

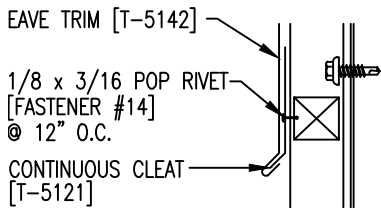

OPTIONAL  
CONTINUOUS CLEAT

FILL END OF RIB W/  
URETHANE SEALANT

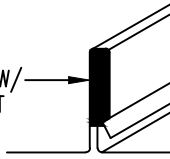

12

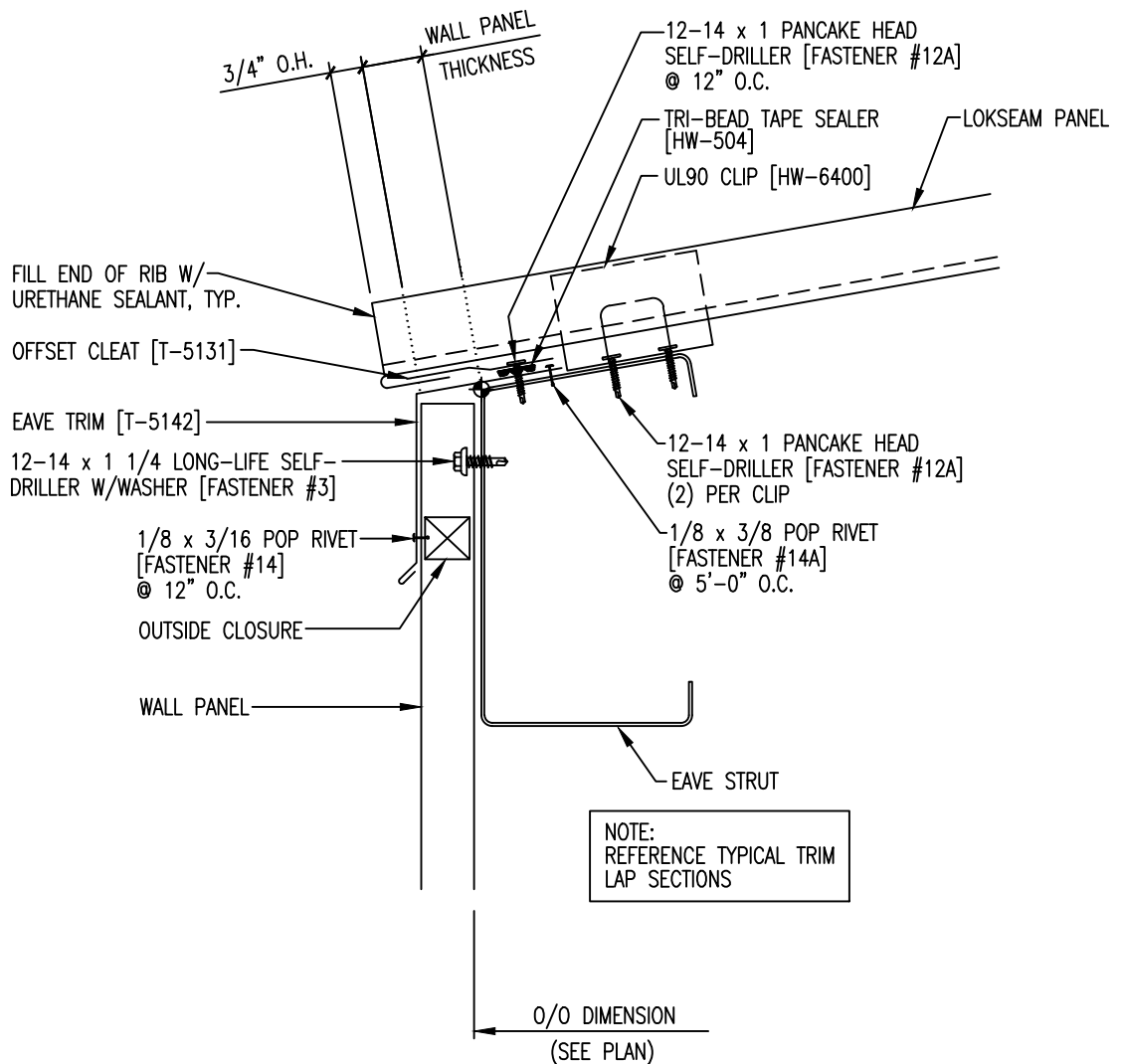

NOTE:  
REFERENCE TYPICAL TRIM  
LAP SECTIONS

O/O DIMENSION  
(SEE PLAN)