

FIELD CUT PANEL RIBS
AND BEND PAN OVER
TO FORM OPEN HEM

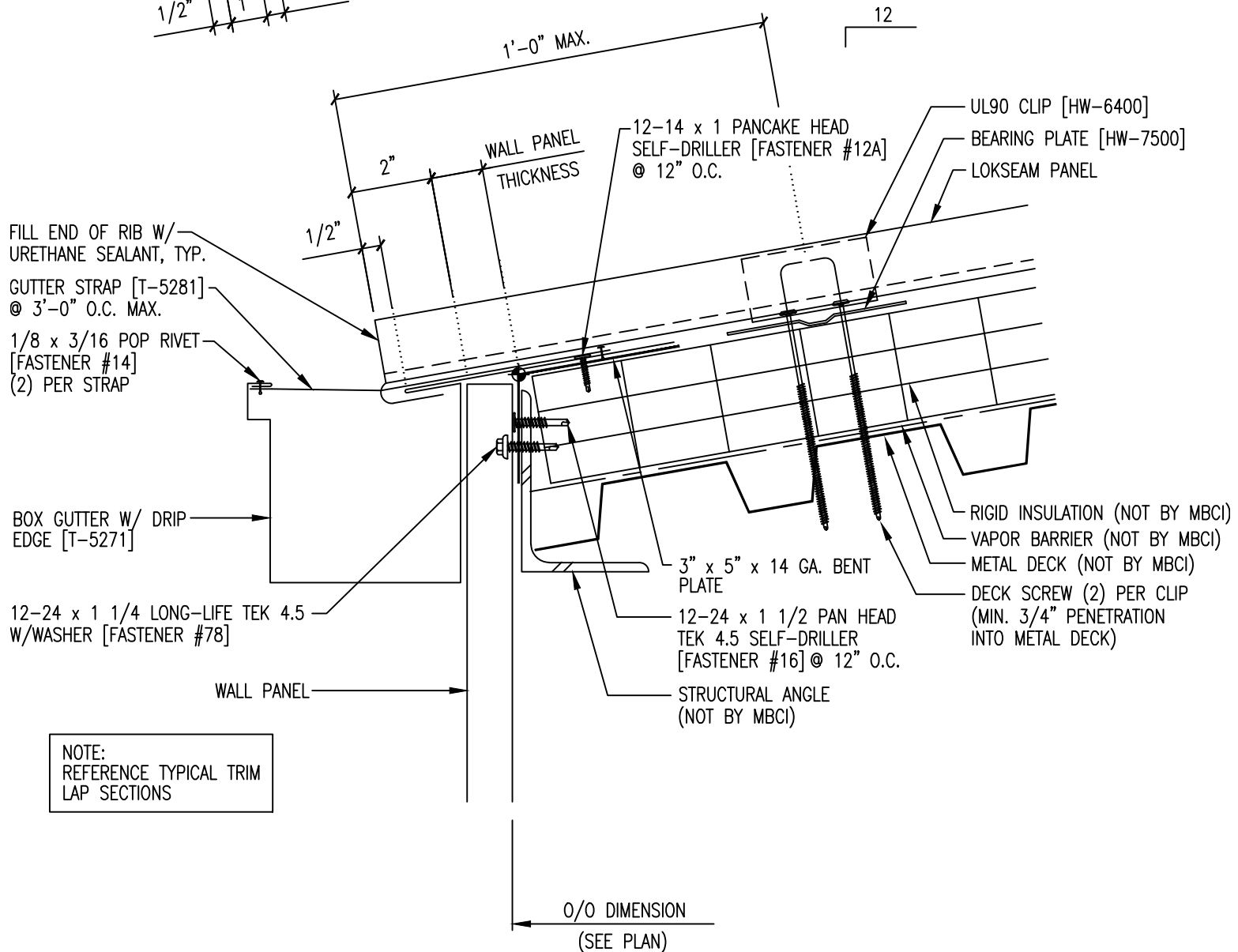
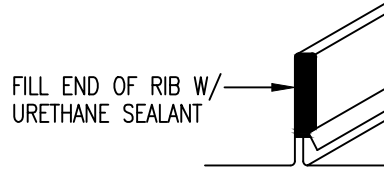
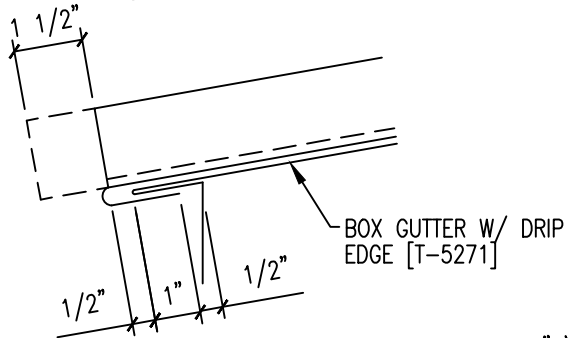

FILL END OF RIB W/
URETHANE SEALANT, TYP.
GUTTER STRAP [T-5281]
@ 3'-0" O.C. MAX.

1/8 x 3/16 POP RIVET
[FASTENER #14]
(2) PER STRAP

BOX GUTTER W/ DRIP
EDGE [T-5271]

12-24 x 1 1/4 LONG-LIFE TEK 4.5
W/WASHER [FASTENER #78]

WALL PANEL

12-14 x 1 PANCAKE HEAD
SELF-DRILLER [FASTENER #12A]
@ 12" O.C.

UL90 CLIP [HW-6400]
BEARING PLATE [HW-7500]
LOKSEAM PANEL

3" x 5" x 14 GA. BENT
PLATE

12-24 x 1 1/2 PAN HEAD
TEK 4.5 SELF-DRILLER
[FASTENER #16] @ 12" O.C.

STRUCTURAL ANGLE
(NOT BY MBCI)

RIGID INSULATION (NOT BY MBCI)
VAPOR BARRIER (NOT BY MBCI)
METAL DECK (NOT BY MBCI)
DECK SCREW (2) PER CLIP
(MIN. 3/4" PENETRATION
INTO METAL DECK)

NOTE:
REFERENCE TYPICAL TRIM
LAP SECTIONS

O/O DIMENSION
(SEE PLAN)