

CRAFTSMAN SB BATTEN CAP [FL-566]
 FILL END W/ URETHANE SEALANT

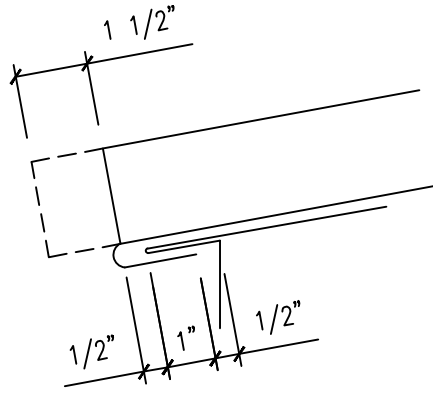

FIELD NOTCH PANEL LEGS AND BEND PAN TO FORM OPEN HEM

PANEL ENGAGEMENT DETAIL

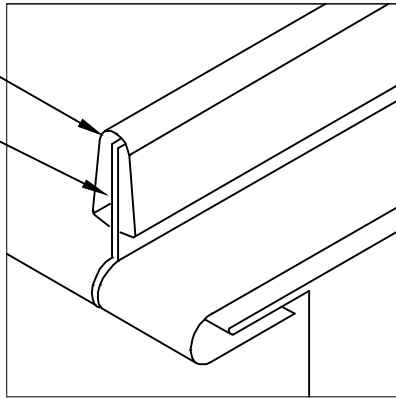