



MasterLine 16[®]

Technical/Installation Information

IMPORTANT NOTICE

READ THIS MANUAL COMPLETELY PRIOR TO BEGINNING THE INSTALLATION OF THE MasterLine 16® WALL SYSTEM. MBCI DETAILS MUST BE FOLLOWED AS A MINIMUM TO INSURE APPROPRIATE WARRANTIES WILL BE ISSUED.

ALWAYS INSPECT EACH AND EVERY PANEL AND ALL ACCESSORIES BEFORE INSTALLATION. NEVER INSTALL ANY PRODUCT IF ITS QUALITY IS IN QUESTION. NOTIFY MBCI IMMEDIATELY IF ANY PRODUCT IS BELIEVED TO BE OUT OF TOLERANCE OR HAS BEEN DAMAGED DURING SHIPMENT.

IF THERE IS A CONFLICT BETWEEN APPROVED ERECTION DRAWINGS PROVIDED OR APPROVED BY MBCI AND THE DETAILS IN THIS MANUAL, THE PROJECT ERECTION DRAWINGS WILL TAKE PRECEDENCE.

© 2022 MBCI, part of **Cornerstone Building Brands, Inc.**

Architectural panels with wide, flat areas are inherently difficult to install without some oil canning being exhibited. As such, these panels should be installed over a true, well-aligned substructure. Extreme care is required and special installation techniques may be necessary, such as crowning the panels with a material like a foam backer rod to prevent or reduce oil canning.

The Engineering data contained herein is for the expressed use of customers and design professionals. Along with this data, it is recommended that the design professional have a copy of the most current version of the North American Specification for the Design of Cold-Formed Steel Structural Members published by the American Iron and Steel Institute to facilitate design. This Specification contains the design criteria for cold-formed steel components. Along with the Specification, the designer should reference the most current building code applicable to the project jobsite in order to determine environmental loads. If further information or guidance regarding cold-formed design practices is desired, please contact the manufacturer.

Descriptions and specifications contained herein were in effect at the time this publication was approved for printing. In a continuing effort to refine and improve products, MBCI reserves the right to discontinue products at any time or change specifications and/or designs without incurring obligation. **To ensure you have the latest information available, please inquire or visit our website at www.mbc.com.** Application details are for illustration purposes only and may not be appropriate for all environmental conditions, building designs or panel profiles. Projects should be designed to conform to applicable building codes, regulations and accepted industry practices. If there is a conflict between this manual and project erection drawings, the erection drawings will take precedence.

For complete performance specifications, product limitations and disclaimers, please consult MBCI's Paint and Galvalume Plus® warranties. Upon receipt of payment in full, these warranties are available upon request for all painted or Galvalume Plus®, prime products. Sample copies can be found at www.mbc.com or contact your local MBCI Sales Representative.

TABLE OF CONTENTS

GENERAL INFORMATION

Installation Guidelines ML-4
General Description ML-5
Architect/Engineer InformationML-6 - ML-7
Product ChecklistML-8 - ML-10

SPECIFICATIONS

Specifications For Metal Wall SystemsML-11 - ML-15

DETAIL

Panel Attachment ML-16
Base Detail with Angle ML-17
Base Detail with Sheathing Notch..... ML-18
Outside Corner Detail..... ML-19
Inside Corner Detail..... ML-20
Parapet Detail..... ML-21
Eave with Box Trim ML-22
Eave with Box Gutter ML-23
Rake with Box Trim ML-24
Door Framing Details ML-25
Door Head Detail..... ML-26
Door Jamb Detail..... ML-27
Window Framing Details ML-28
Window Sill Details..... ML-29
Window Jamb Detail..... ML-30
Window Head Detail..... ML-31
Panel Lap ML-32
Flat Splice Trim..... ML-33
Reveal Splice Trim. ML-34
Termination ML-35



GENERAL INFORMATION

INSTALLATION GUIDELINES

I. Pre-Order

- A. Prior to ordering panels, all dimensions should be confirmed by field measurements.

II. Jobsite Storage and Handling

- A. Check the shipment against the shipping list.
- B. Damaged material must be noted on Bill of Lading.
- C. Panels should be handled carefully. A spreader bar of appropriate length is recommended for hoisting.
- D. Check to see that moisture has not formed inside the bundles during shipment. If moisture is present, panels should be wiped dry, then restacked and loosely covered so that air can circulate between the panels.

III. Application Checklist

- A. Check substructure for proper alignment and uniformity to avoid panel distortion.
- B. Periodic check of panel alignment is crucial to proper panel installation.
- C. When installing panels over blanket insulation, it may be necessary to push middle of panel in as clips and fasteners are installed to maintain a consistent flat surface along the wall.
- D. Keep panels clean during installation. Do not allow panels to come into contact with or water runoff from lead, copper, or graphite.

GENERAL INFORMATION

GENERAL DESCRIPTION

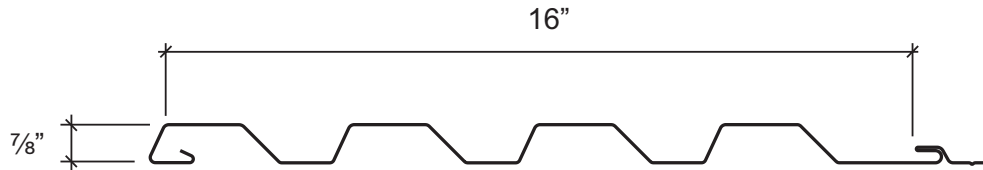

Coverage Width - 16"

Panel Attachment - Fastener Leg

Panel Substrate - Galvalume Plus[®]

Panel Finish - Smooth (standard) or Embossed (optional for 24 & 22 gauge only)

Gauge - 24 and 22

PRODUCT SELECTION CHART

	Galvalume Plus [®]	Signature [®] 300*	Signature [®] 300* Metallic	Signature [®] 200*
24 gauge	●	●	●	●
22 gauge	●	■	■	■

Signature is a registered trademark of NCI Group, Inc. Galvalume Plus is a registered trademark of BIEC International.

- — Available in any quantity.
- — Minimum quantity may be required.

*See architectural color chart for available colors.

NOTICE
 Contact MBCI for Positive and Negative Wind Load information.



GENERAL INFORMATION

ARCHITECT/ENGINEER INFORMATION

1. MasterLine 16® architectural wall panel is a concealed fastener panel designed to be used in horizontal or vertical applications.
2. Panel coverage is 16" and panels are available in 24, and 22 gauge thicknesses. Heavier gauges and embossing minimizes oil canning. Oil canning is not a cause for rejection.
3. Panels may be ordered with factory applied mastic to achieve ratings shown on page ML-7 for ASTM E283 and E331 Air and Water Leakage.
4. Wall framing must be plumb and square and in plane ($\pm 1/4"$ in 20'). Depending upon the panel end detail selected, double studs may be required at panel end laps.
5. The panel face will be protected with strippable film. Exposure to sunlight for an extended period of time (over one week) may cause the strippable film to aggressively adhere to the metal and become difficult or impossible to remove. Strippable film should always be removed from panels as they are installed.
6. Panels may be installed over a wide variety of substrates. Panels can be applied over concrete and masonry walls by using sub girts. Panels can also be applied over bare studs, plywood, continuous insulation and various types of sheathing. Substrate material must be in plane ($1/4"$ in 20'). Any inconsistencies or misalignment at sheathing seams may telegraph through the panels.
7. For continuous panel runs over 35', please inquire.

GENERAL INFORMATION

MASTERLINE 16" 24 GA. NEGATIVE DESIGN LOADS (psf)

Span	Negative Design Load	Positive Design Load
2.00	70.20	156.00
2.50	65.87	145.60
3.00	61.54	135.20
3.50	57.20	124.80
4.00	52.87	114.40
4.50	48.54	104.00
5.00	44.20	93.60
5.50	39.87	83.20
6.00	35.54	72.80
6.50	31.20	62.40
7.00	26.87	52.00
7.50	22.54	41.60
8.00	18.20	31.20

Notes:

- 1) The above loads were derived from uplift tests done in accordance with ASTM E-1592.
- 2) Test results are highlighted.
- 3) All values are interpolated and/or extrapolated from tests performed at spans of 2'-0" and 8'-0".
- 4) Design Load contains a 2.00 factor of safety.
- 5) These values do not consider fastener pullout or pullover, clip attachment must be designed separately.
- 6) The use of any accessories including but not limited to clips, fasteners, and support plates (eave, backup, rake, etc.) other than those provided by the manufacturer may damage panels, void all warranties and will void all engineering data.
- 7) This material is subject to change without notice. Please contact MBCI for most current data.

Effective Date: September 23, 2014

The Engineering data contained herein is for the expressed use of customers and design professionals. Along with this data, it is recommended that the design professional have a copy of the most current version of the North American Specification for the Design of Cold-Formed Steel Structural Members published by the American Iron and Steel Institute to facilitate design. This Specification contains the design criteria for cold-formed steel components. Along with the Specification, the designer should reference the most current building code applicable to the project jobsite in order to determine environmental loads. If further information or guidance regarding cold-formed design practices is desired, please contact the manufacturer.

Profile	ASTM E 283-04 Air Leakage		ASTM E 331-00 Water Penetration	
	Pressure Differential	Leakage Rate	Pressure Differential	Infiltration Rate
MasterLine 16" -24 Ga.	6.24 PSF	.002 CFM/sq. ft.	20.00 PSF	No Leakage
	12.00 PSF	.003 CFM/sq. ft.		

GENERAL INFORMATION

PRODUCT CHECKLIST

MasterLine 16® Panel																																		
Outside Corner	Inside Corner	Base Trim																																
<table style="width: 100%; border-collapse: collapse;"> <thead> <tr> <th style="text-align: left;">PART NO.</th> <th style="text-align: left;">LENGTH</th> <th style="text-align: left;">GIRTH</th> <th style="text-align: center;"><input type="checkbox"/></th> </tr> </thead> <tbody> <tr> <td>T-5505</td> <td>10'-2"</td> <td>7"</td> <td style="text-align: center;"><input type="checkbox"/></td> </tr> <tr> <td>T-5506</td> <td>20'-2"</td> <td>7"</td> <td style="text-align: center;"><input type="checkbox"/></td> </tr> </tbody> </table>	PART NO.	LENGTH	GIRTH	<input type="checkbox"/>	T-5505	10'-2"	7"	<input type="checkbox"/>	T-5506	20'-2"	7"	<input type="checkbox"/>	<table style="width: 100%; border-collapse: collapse;"> <thead> <tr> <th style="text-align: left;">PART NO.</th> <th style="text-align: left;">LENGTH</th> <th style="text-align: left;">GIRTH</th> <th style="text-align: center;"><input type="checkbox"/></th> </tr> </thead> <tbody> <tr> <td>T-5507</td> <td>10'-2"</td> <td>7"</td> <td style="text-align: center;"><input type="checkbox"/></td> </tr> <tr> <td>T-5508</td> <td>20'-2"</td> <td>7"</td> <td style="text-align: center;"><input type="checkbox"/></td> </tr> </tbody> </table>	PART NO.	LENGTH	GIRTH	<input type="checkbox"/>	T-5507	10'-2"	7"	<input type="checkbox"/>	T-5508	20'-2"	7"	<input type="checkbox"/>	<table style="width: 100%; border-collapse: collapse;"> <thead> <tr> <th style="text-align: left;">PART NO.</th> <th style="text-align: left;">LENGTH</th> <th style="text-align: left;">GIRTH</th> <th style="text-align: center;"><input type="checkbox"/></th> </tr> </thead> <tbody> <tr> <td>T-5534</td> <td>10'-2"</td> <td>4 3/4"</td> <td style="text-align: center;"><input type="checkbox"/></td> </tr> </tbody> </table>	PART NO.	LENGTH	GIRTH	<input type="checkbox"/>	T-5534	10'-2"	4 3/4"	<input type="checkbox"/>
PART NO.	LENGTH	GIRTH	<input type="checkbox"/>																															
T-5505	10'-2"	7"	<input type="checkbox"/>																															
T-5506	20'-2"	7"	<input type="checkbox"/>																															
PART NO.	LENGTH	GIRTH	<input type="checkbox"/>																															
T-5507	10'-2"	7"	<input type="checkbox"/>																															
T-5508	20'-2"	7"	<input type="checkbox"/>																															
PART NO.	LENGTH	GIRTH	<input type="checkbox"/>																															
T-5534	10'-2"	4 3/4"	<input type="checkbox"/>																															
Support Zee	Cee Closure	Jamb/Sill Case Trim																																
<table style="width: 100%; border-collapse: collapse;"> <thead> <tr> <th style="text-align: left;">PART NO.</th> <th style="text-align: left;">LENGTH</th> <th style="text-align: left;">GIRTH</th> <th style="text-align: center;"><input type="checkbox"/></th> </tr> </thead> <tbody> <tr> <td>T-5526</td> <td>10'-2"</td> <td>2 3/4"</td> <td style="text-align: center;"><input type="checkbox"/></td> </tr> </tbody> </table>	PART NO.	LENGTH	GIRTH	<input type="checkbox"/>	T-5526	10'-2"	2 3/4"	<input type="checkbox"/>	<table style="width: 100%; border-collapse: collapse;"> <thead> <tr> <th style="text-align: left;">PART NO.</th> <th style="text-align: left;">LENGTH</th> <th style="text-align: left;">GIRTH</th> <th style="text-align: center;"><input type="checkbox"/></th> </tr> </thead> <tbody> <tr> <td>T-5510</td> <td>10'-2"</td> <td>5 1/2"</td> <td style="text-align: center;"><input type="checkbox"/></td> </tr> </tbody> </table>	PART NO.	LENGTH	GIRTH	<input type="checkbox"/>	T-5510	10'-2"	5 1/2"	<input type="checkbox"/>	<table style="width: 100%; border-collapse: collapse;"> <thead> <tr> <th style="text-align: left;">PART NO.</th> <th style="text-align: left;">LENGTH</th> <th style="text-align: left;">GIRTH</th> <th style="text-align: center;"><input type="checkbox"/></th> </tr> </thead> <tbody> <tr> <td>T-5517</td> <td>10'-2"</td> <td>6"</td> <td style="text-align: center;"><input type="checkbox"/></td> </tr> </tbody> </table>	PART NO.	LENGTH	GIRTH	<input type="checkbox"/>	T-5517	10'-2"	6"	<input type="checkbox"/>								
PART NO.	LENGTH	GIRTH	<input type="checkbox"/>																															
T-5526	10'-2"	2 3/4"	<input type="checkbox"/>																															
PART NO.	LENGTH	GIRTH	<input type="checkbox"/>																															
T-5510	10'-2"	5 1/2"	<input type="checkbox"/>																															
PART NO.	LENGTH	GIRTH	<input type="checkbox"/>																															
T-5517	10'-2"	6"	<input type="checkbox"/>																															

GENERAL INFORMATION

PRODUCT CHECKLIST

<p>Flat Splice Trim</p> <table border="1"> <thead> <tr> <th>PART NO.</th> <th>LENGTH</th> <th>GIRTH</th> <th></th> </tr> </thead> <tbody> <tr> <td>T-5520</td> <td>10'-2"</td> <td>5"</td> <td><input type="checkbox"/></td> </tr> <tr> <td>T-5521</td> <td>14'-0"</td> <td>5"</td> <td><input type="checkbox"/></td> </tr> </tbody> </table>	PART NO.	LENGTH	GIRTH		T-5520	10'-2"	5"	<input type="checkbox"/>	T-5521	14'-0"	5"	<input type="checkbox"/>	<p>Reveal Splice Trim</p> <table border="1"> <thead> <tr> <th>PART NO.</th> <th>LENGTH</th> <th>GIRTH</th> <th></th> </tr> </thead> <tbody> <tr> <td>T-5523</td> <td>10'-2"</td> <td>7½"</td> <td><input type="checkbox"/></td> </tr> <tr> <td>T-5524</td> <td>14'-0"</td> <td>7½"</td> <td><input type="checkbox"/></td> </tr> </tbody> </table>	PART NO.	LENGTH	GIRTH		T-5523	10'-2"	7½"	<input type="checkbox"/>	T-5524	14'-0"	7½"	<input type="checkbox"/>	<p>Panel Cleat</p> <table border="1"> <thead> <tr> <th>PART NO.</th> <th>LENGTH</th> <th>GIRTH</th> <th></th> </tr> </thead> <tbody> <tr> <td>T-5530</td> <td>10'-2"</td> <td>3¼"</td> <td><input type="checkbox"/></td> </tr> </tbody> </table>	PART NO.	LENGTH	GIRTH		T-5530	10'-2"	3¼"	<input type="checkbox"/>											
PART NO.	LENGTH	GIRTH																																											
T-5520	10'-2"	5"	<input type="checkbox"/>																																										
T-5521	14'-0"	5"	<input type="checkbox"/>																																										
PART NO.	LENGTH	GIRTH																																											
T-5523	10'-2"	7½"	<input type="checkbox"/>																																										
T-5524	14'-0"	7½"	<input type="checkbox"/>																																										
PART NO.	LENGTH	GIRTH																																											
T-5530	10'-2"	3¼"	<input type="checkbox"/>																																										
<p>Head Trim</p> <table border="1"> <thead> <tr> <th>PART NO.</th> <th>LENGTH</th> <th>GIRTH</th> <th></th> </tr> </thead> <tbody> <tr> <td>T-5511</td> <td>3'-6"</td> <td>6⅞"</td> <td><input type="checkbox"/></td> </tr> <tr> <td>T-5513</td> <td>10'-4"</td> <td>6⅞"</td> <td><input type="checkbox"/></td> </tr> <tr> <td>T-5515</td> <td>14'-4"</td> <td>6⅞"</td> <td><input type="checkbox"/></td> </tr> </tbody> </table>	PART NO.	LENGTH	GIRTH		T-5511	3'-6"	6⅞"	<input type="checkbox"/>	T-5513	10'-4"	6⅞"	<input type="checkbox"/>	T-5515	14'-4"	6⅞"	<input type="checkbox"/>	<p>Sheathing Support Angle</p> <ul style="list-style-type: none"> • Use with ½"-1" or 3½"-4" Thick Sheathing <p style="text-align: right;">HW-4651 <input type="checkbox"/></p>	<p>Sheathing Support Angle</p> <ul style="list-style-type: none"> • Use with 1½"-2" or 2½"-3" Thick Sheathing <p style="text-align: right;">HW-4652 <input type="checkbox"/></p>																											
PART NO.	LENGTH	GIRTH																																											
T-5511	3'-6"	6⅞"	<input type="checkbox"/>																																										
T-5513	10'-4"	6⅞"	<input type="checkbox"/>																																										
T-5515	14'-4"	6⅞"	<input type="checkbox"/>																																										
<p>Door Jamb Cleat</p> <table border="1"> <thead> <tr> <th>PART NO.</th> <th>LENGTH</th> <th>GIRTH</th> <th></th> </tr> </thead> <tbody> <tr> <td>T-5540</td> <td>10'-2"</td> <td>3"</td> <td><input type="checkbox"/></td> </tr> </tbody> </table>	PART NO.	LENGTH	GIRTH		T-5540	10'-2"	3"	<input type="checkbox"/>	<p>Two Piece Jamb Trim</p> <table border="1"> <thead> <tr> <th>PART NO.</th> <th>DIM "A"</th> <th>SHEATHING THICKNESS</th> <th>LENGTH</th> <th>GIRTH</th> <th></th> </tr> </thead> <tbody> <tr> <td>T-5541</td> <td>1½"</td> <td>½"</td> <td>10'-2"</td> <td>4¾"</td> <td><input type="checkbox"/></td> </tr> <tr> <td>T-5542</td> <td>1¾"</td> <td>¾"</td> <td>10'-2"</td> <td>5"</td> <td><input type="checkbox"/></td> </tr> <tr> <td>T-5543</td> <td>2"</td> <td>1"</td> <td>10'-2"</td> <td>5¼"</td> <td><input type="checkbox"/></td> </tr> <tr> <td>T-5544</td> <td>2½"</td> <td>1½"</td> <td>10'-2"</td> <td>5¾"</td> <td><input type="checkbox"/></td> </tr> <tr> <td>T-5545</td> <td>3"</td> <td>2"</td> <td>10'-2"</td> <td>6¼"</td> <td><input type="checkbox"/></td> </tr> </tbody> </table>	PART NO.	DIM "A"	SHEATHING THICKNESS	LENGTH	GIRTH		T-5541	1½"	½"	10'-2"	4¾"	<input type="checkbox"/>	T-5542	1¾"	¾"	10'-2"	5"	<input type="checkbox"/>	T-5543	2"	1"	10'-2"	5¼"	<input type="checkbox"/>	T-5544	2½"	1½"	10'-2"	5¾"	<input type="checkbox"/>	T-5545	3"	2"	10'-2"	6¼"	<input type="checkbox"/>
PART NO.	LENGTH	GIRTH																																											
T-5540	10'-2"	3"	<input type="checkbox"/>																																										
PART NO.	DIM "A"	SHEATHING THICKNESS	LENGTH	GIRTH																																									
T-5541	1½"	½"	10'-2"	4¾"	<input type="checkbox"/>																																								
T-5542	1¾"	¾"	10'-2"	5"	<input type="checkbox"/>																																								
T-5543	2"	1"	10'-2"	5¼"	<input type="checkbox"/>																																								
T-5544	2½"	1½"	10'-2"	5¾"	<input type="checkbox"/>																																								
T-5545	3"	2"	10'-2"	6¼"	<input type="checkbox"/>																																								

GENERAL INFORMATION

PRODUCT CHECKLIST

<p>Outside Closure - Metal</p> <p style="text-align: center;">Left Closure 1.33 .78</p> <p style="text-align: center;">Right Closure 1.33 .78</p> <p style="text-align: right;">HW-4067LH <input type="checkbox"/> HW-4067RH <input type="checkbox"/></p>	<p>Outside Closure - Foam</p> <p style="text-align: right;">HW-433 <input type="checkbox"/></p>	<p>1/2" x 3/32" Tape Sealant</p> <p style="text-align: right;">HW-507 <input type="checkbox"/></p>
<p>Tube Sealant</p> <p style="text-align: right;">Urethane HW-540 <input type="checkbox"/> Non-Skinning Butyl HW-549 <input type="checkbox"/></p>	<p>Fastener #4A</p> <p>1/4" x 14 x 7/8" Lap 5/16" Hex Washer Head w/EDPM Washer <input type="checkbox"/></p>	<p>Fastener #14</p> <p>1/8" x 0.337" Pop Rivet <input type="checkbox"/></p>
<p>Fastener #12A</p> <p>12 x 11 x 1" Pancake head with #3 Drill Point #2 Quadrex Drive <input type="checkbox"/></p>	<p>Fastener #17B</p> <p>12-14 x 1 1/2" with #3 Drill Point 5/16" Hex Washer Head with EDPM Washer <input type="checkbox"/></p>	<p>Fastener #28</p> <p>12-14 x 2" with #2 Drill Point 5/16" Hex Washer Head with EDPM Washer <input type="checkbox"/></p>
<p>Fastener #209</p> <p>14 - 10 x 2" Deck Screw #3 Phillips Truss Head <input type="checkbox"/></p>	<p>Fastener #210</p> <p>14 - 10 x 3" Deck Screw #3 Phillips Truss Head <input type="checkbox"/></p>	<p>Fastener #211</p> <p>14 - 10 x 4" Deck Screw #3 Phillips Truss Head <input type="checkbox"/></p>

SPECIFICATIONS

SECTION 07 42 13.13 FORMED METAL WALL PANELS

PART 1 - GENERAL

1.1 SECTION INCLUDES

- A. Ribbed-profile, concealed fastener metal wall panels, with related metal trim, and accessories.

1.2 RELATED REQUIREMENTS

Specifier: If retaining this optional article, edit list below to correspond to Project.

- A. Division 01 Section "Sustainable Design Requirements" for related LEED general requirements.
- B. Division 05 Section "Structural Steel Framing" for steel framing supporting metal panels.
- C. Division 05 Section "Cold-Formed Metal Framing" for cold-formed metal framing supporting metal panels.
- D. Division 07 Section "Thermal Insulation" for thermal insulation installed behind metal panels.
- E. Division 07 Section "Air Barriers" for air barriers within wall assembly and adjacent to wall assembly.
- F. Division 07 Section "Metal Soffit Panels" for soffit panels installed with metal wall panels.
- G. Division 07 Section "Sheet Metal Flashing and Trim" for sheet metal flashing items in addition to items specified in this Section.
- H. Division 13 Section "Metal Building Systems" for steel framing supporting metal panels.

1.3 REFERENCES

Specifier: If retaining this optional article, edit list below to correspond to Project.

- A. American Architectural Manufacturer's Association (AAMA): www.aamanet.org:
 1. AAMA 621 - Voluntary Specifications for High Performance Organic Coatings on Coil Coated Architectural Hot Dipped Galvanized (HDG) & Zinc-Aluminum Coated Steel Substrates.
 2. AAMA 809.2 Voluntary Specification Non-Drying Sealants.
- B. American Society of Civil Engineers (ASCE): www.asce.org/codes-standards:
 1. ASCE 7 - Minimum Design Loads for Buildings and Other Structures.
- C. ASTM International (ASTM): www.astm.org:
 1. ASTM A755 - Specification for Steel Sheet, Metallic Coated by the Hot-Dip Process and Pre-painted by the Coil-Coating Process for Exterior Exposed Building Products.
 2. ASTM A792/A792M - Standard Specification for Steel Sheet, 55% Aluminum-Zinc Alloy-Coated by the Hot-Dip Process.
 3. ASTM C920 - Specification for Elastomeric Joint Sealants.

4. ASTM D2244 - Test Method for Calculation of Color Differences from Instrumentally Measured Color Coordinates.
 5. ASTM D4214 - Test Methods for Evaluating Degree of Chalking of Exterior Paint Films.
 6. ASTM E283 - Standard Test Method for Determining Rate of Air Leakage Through Exterior Windows, Curtain Walls, and Doors Under Specified Pressure Differences Across the Specimen.
 7. ASTM E331 - Standard Test Method for Water Penetration of Exterior Windows, Skylights, Doors, and Curtain Walls by Uniform Static Air Pressure Difference.
 8. ASTM E1592 - Standard Test Method for Structural Performance of Sheet Metal Roof and Siding Systems by Uniform Static Air Pressure Difference.
- D. International Accreditation Service (IAS):
 1. IAS AC472 Accreditation Criteria for Inspection Programs for Manufacturers of Metal Building Systems, Part B.
 - E. US Green Building Council (USGBC): www.usgbc.org:
 1. Leadership in Energy and Environmental Design (LEED) Green Building Rating System.

1.4 QUALITY ASSURANCE

- A. Manufacturer/Source: Provide metal panel assemblies and accessories from a single manufacturer accredited under IAS AC472, Part B.
- B. Manufacturer Qualifications: Approved manufacturer listed in this Section with minimum five years experience in manufacture of similar products in successful use in similar applications.

Specifier: Retain paragraph below if Owner allows substitutions but requires control over qualifying of substituted manufacturers.

1. Approval of Comparable Products: Submit the following in accordance with project substitution requirements, within time allowed for substitution review:
 - a. Product data, including certified independent test data indicating compliance with requirements.
 - b. Samples of each component.
 - c. Sample shop drawings from similar project.
 - d. Project References: Minimum of five installations not less than three years old, with Owner and Architect contact information.
 - e. Sample warranty.
 - f. Certificate of accreditation under IAS AC472 Part B.

SPECIFICATIONS

2. Substitutions following award of contract are not allowed except as stipulated in Division 01 General Requirements.
 3. Approved manufacturers must meet separate requirements of Submittals Article.
- C. Installer Qualifications: Experienced Installer with minimum of five years experience with successfully completed projects of a similar nature and scope.
1. Installer's Field Supervisor: Experienced mechanic supervising work on site whenever work is underway.

Specifier: Retain paragraph below and edit as appropriate for Federal projects and for public works projects utilizing Federal funds; consult with project Contracting Officer. Coordinate with Submittals Article.

- D. Buy American Compliance: Materials provided under work of this Section shall comply with the following requirements:
1. Buy American Act of 1933 BAA-41 U.S.C §§ 10a – 10d.
 2. Buy American provisions of Section 1605 of the American Recovery and Reinvestment Act of 2009 (ARRA).
- E. Steel Construction Publications: Comply with published recommendations in the following, unless more stringent requirements are indicated.
1. American Institute of Steel Construction (AISC): "Steel Construction Manual."
 2. American Iron and Steel Institute (AISI): "Cold Formed Steel Design Manual."

1.5 ADMINISTRATIVE REQUIREMENTS

- A. Preinstallation Meeting: Prior to erection of framing, conduct preinstallation meeting at site attended by Owner, Architect, metal panel installer, metal panel manufacturer's technical representative, inspection agency and related trade contractors.
1. Coordinate building framing in relation to metal panel system.
 2. Coordinate openings and penetrations of metal panel system.
 3. Coordinate work of Division 07 Sections "Roof Specialties" and "Roof Accessories" and openings and penetrations and manufacturer's accessories with installation of metal panels.

1.6 ACTION SUBMITTALS

- A. Product Data: Manufacturer's data sheets for specified products. Include data indicating compliance with performance requirements.

Specifier: Retain and edit below to comply with Project requirements for LEED or other sustainable design requirements.

- B. LEED Submittals:
1. Credit MR 4 Recycled Content: Product data indicating the following:

- a. Material costs for each product having recycled content.
 - b. Percentages by weight of post-consumer and pre-consumer recycled content for each item.
 - c. Total weight of products provided.
2. Credit IEQ 4.1 Low-Emitting Materials - Adhesives and Sealants: Product data for sealants and sealant primers used inside the weatherproofing system, indicating VOC content.

- C. Shop Drawings: Show layouts of metal panels. Include details of each condition of installation, panel profiles, and attachment to building. Provide details at a minimum scale 1-1/2-inch per foot of edge conditions, joints, fastener and sealant placement, flashings, openings, penetrations, and special details. Make distinctions between factory and field assembled work.
1. Indicate points of supporting structure that must coordinate with metal panel system installation.
 2. Include structural data indicating compliance with performance requirements and requirements of local authorities having jurisdiction.
- D. Samples for Initial Selection: For each exposed product specified including sealants. Provide representative color charts of manufacturer's full range of colors.
- E. Samples for Verification: Provide 12-inch- (305 mm-) long section of each metal panel profile. Provide color chip verifying color selection.

1.7 INFORMATIONAL SUBMITTALS

- A. Product Test Reports: Indicating compliance of products with requirements.
- B. Qualification Information: For Installer firm and Installer's field supervisor.
- C. IAS Accreditation Certificate: Indicating that manufacturer is accredited under provisions of IAS AC472 Part B.
- D. Buy American Certification: Manufacturers' letters of compliance acceptable to authorities having jurisdiction, indicating that products comply with requirements.
- E. Florida State Building Code Certificate: Indicating that products comply with requirements of Florida State Building Code. www.floridabuilding.org/pr/pr_app_srch.aspx
- F. Manufacturer's warranty: Unexecuted sample copy of manufacturer's warranty.

1.8 CLOSEOUT SUBMITTALS

- A. Maintenance data.
- B. Manufacturer's Warranty: Executed copy of manufacturer's warranty.

1.9 DELIVERY, STORAGE, AND HANDLING

- A. Protect products of metal panel system during

SPECIFICATIONS

shipping, handling, and storage to prevent staining, denting, deterioration of components or other damage. Protect panels and trim bundles during shipping.

1. Deliver, unload, store, and erect metal panels and accessory items without misshaping panels or exposing panels to surface damage from weather or construction operations.
2. Store in accordance with Manufacturer's written instruction. Provide wood collars for stacking and handling in the field.
3. Shield foam insulated metal panels from direct sunlight until installation.

1.10 WARRANTY

Specifier: Warranty terms below are available from MBCI. Verify that other allowable manufacturers furnish warranty meeting requirements.

- A. Special Manufacturer's Warranty: On manufacturer's standard form, in which manufacturer agrees to repair or replace metal panel assemblies that fail in materials and workmanship within [one] year from date of Substantial Completion.
- B. Special Panel Finish Warranty: On Manufacturer's standard form, in which Manufacturer agrees to repair or replace metal panels that evidence deterioration of factory-applied finish within the warranty period, as follows:

Specifier: Retain finish warranty paragraph that corresponds to selected metal panel finish system. Several exotic and metallic colors are available from MBCI with limited warranty periods; verify warranty period for selected colors with manufacturer.

1. Fluoropolymer Two-Coat System:
 - a. Basis of Design System: MBCI, Signature 300.
 - b. Color fading in excess of 5 Hunter units per ASTM D2244.
 - c. Chalking in excess of No. 8 rating per ASTM D4214.
 - d. Failure of adhesion, peeling, checking, or cracking.
 - e. Warranty Period: [40] years from date of Substantial Completion.
2. Modified Silicone-Polyester Two-Coat System:
 - a. Basis of Design System: MBCI, Signature 200.
 - b. Color fading in excess of 7 Hunter units per ASTM D2244.
 - c. Chalking in excess of No. 6 rating per ASTM D4214.
 - d. Failure of adhesion, peeling, checking, or cracking.
 - e. Warranty Period: [30] years from date of Substantial Completion.

PART 2 - PRODUCTS

2.1 MANUFACTURER

Specifier: Retain basis of design manufacturer and products

listed in this Article where allowed. If inserting comparable manufacturers, carefully review products and engineering capabilities in relation to requirements of this Section, to ensure that other approved manufacturers offer products meeting MBCI's standards.

A. Basis of Design Manufacturer: MBCI Metal Roof and Wall Systems, Division of NCI Group, Inc.; Houston TX. Tel: (877)713-6224; Email: info@mbsci.com; Web: www.mbsci.com.

1. Provide basis of design product [, or comparable product approved by Architect prior to bid].

2.2 PERFORMANCE REQUIREMENTS

A. General: Provide metal panel system meeting performance requirements as determined by application of specified tests by a qualified testing facility on manufacturer's standard assemblies.

Specifier: "Recycled Content" Paragraph below describes calculation utilized for LEED-NC Credit MR 4. Modify as required to meet project recycled content requirements, or delete if recycled content requirements are stipulated solely in Division 01 Section "Sustainable Design Requirements."

B. Recycled Content: For Steel Products: Postconsumer recycled content plus one-half of preconsumer recycled content not less than [25] percent.

C. Structural Performance: Provide metal panel assemblies capable of withstanding the effects of indicated loads and stresses within limits and under conditions indicated, as determined by ASTM E1592:

Specifier: Consult structural engineer and edit below as required by local codes. Insert structural data below if not indicated on drawings. Select applicable deflection limit.

1. Wind Loads: Determine loads based on uniform pressure, importance factor, exposure category, and basic wind speed indicated on drawings.
 - a. Wind Negative Pressure: Certify capacity of metal panels by actual testing of proposed assembly.
2. Deflection Limits: Withstand inward and outward wind-load design pressures in accordance with applicable building code with maximum deflection of 1/120 of the span with no evidence of failure.
3. Seismic Performance: Comply with ASCE 7 Sections 9, "Earthquake Loads."
- D. Florida State Building Code Compliance: Provide metal roof and wall panels complying with requirements for installation under Florida State Building Code outside of high velocity wind zone.
- E. Wall Panel Air Infiltration, ASTM E283:
 1. Maximum 0.002 cfm/sq. ft. (0.010 L/s per sq.m) at static air pressure difference of 6.24 lbf/sq. ft. (300 Pa.)
 2. Maximum 0.003 cfm/sq. ft. (0.015 L/s per sq.m) at static air pressure difference of 12 lbf/sq. ft. (575 Pa.)

SPECIFICATIONS

- F. Wall Panel Water Penetration Static Pressure, ASTM E331: No uncontrolled water penetration at a static pressure of 20 lbf/sq. ft. (958 Pa).
- G. Thermal Movements: Allow for thermal movements from variations in both ambient and internal temperatures. Accommodate movement of support structure caused by thermal expansion and contraction. Allow for deflection and design for thermal stresses caused by temperature differences from one side of the panel to the other.

2.3 FORMED METAL WALL PANELS

- A. Ribbed-Profile, Concealed Fastener Metal Wall Panels: Structural metal panels consisting of formed metal sheet with fastener leg for concealed attachment to wall framing.
 - 1. Basis of Design: MBCI, ?

Specifier: Material description below corresponds to BIEC International, Inc. <http://galvalume.com/> Galvalume substrate, available Prepainted from MBCI. Second paragraph below describes Galvalume Plus with clear acrylic coating for use as exposed metallic finish.

- 2. Aluminum-Zinc Alloy-Coated Steel Sheet: ASTM A792/A792M, structural quality, Grade 50, Coating Class AZ50 (Grade 340, Coating Class AZM150), prepainted by the coil-coating process per ASTM A755/A755M.

Specifier: Prior to selecting metal thickness and panel thickness below, consult manufacturer's span tables and review selection against panel thickness requirements and span condition. Select appropriate panel configuration to meet requirements of design wind pressure. Important: Consult this document when specifying gauge with the intent that it meet a prescriptive decimal thickness requirement in addition to strength performance requirements. ([Click Here to View](#))

- a. Nominal Thickness: [24 gauge] [22 gauge] coated thickness, with [smooth] [stucco embossed] surface.
 - 1) Exterior Finish: [Modified silicone-polyester two-coat system] [Fluoropolymer two-coat system] [Fluoropolymer two-coat metallic color system] [Exposed Galvalume Plus coating].
 - 2) Color: [As indicated] [As selected by Architect from manufacturer's standard colors] [Match Architect's custom color].
- 3. Panel Width: 16 inches (406 mm).
- 4. Panel Thickness: 7/8 inch (22 mm).

2.4 MISCELLANEOUS MATERIALS

- A. General: Provide complete metal panel assemblies incorporating trim, copings, fasciae, gutters and downspouts, and miscellaneous flashings. Provide required fasteners, closure strips, and sealants as indicated in manufacturer's written instructions.

- B. Flashing and Trim: Match material, thickness, and finish of metal panels.
- C. Panel Fasteners: Self-tapping screws and other acceptable fasteners recommended by metal panel manufacturer. Where exposed fasteners cannot be avoided, supply corrosion-resistant fasteners with heads matching color of metal panels by means of factory-applied coating, with weathertight resilient washers.
- D. Panel Sealants:
 - 1. VOC Content of Interior Sealants: Sealants used inside the weatherproofing system shall comply with the following limits for VOC content when calculated according to 40 CFR 59, Subpart D (EPA Method 24):
 - a. Architectural Sealants: 250 g/L.
 - 2. Factory-Applied Seam Sealant: Manufacturer's standard hot-melt type.
 - 3. Concealed Joint Sealant: Non-curing butyl, AAMA 809.2.
 - 4. Elastomeric Joint Sealant: Urethane sealant, single-component, ASTM C920 Type S, Grade NS, Class 25, Use NT, A, M, G, O.
 - 5. Foam Tape: Manufacturer's standard self-adhering type.

2.5 FABRICATION

- A. General: Provide factory fabricated and finished metal panels, trim, and accessories meeting performance requirements, indicated profiles, and structural requirements.
- B. Sheet Metal Flashing and Trim: Fabricate flashing and trim to comply with manufacturer's written instructions, approved shop drawings, and project drawings.

2.6 FINISHES

- A. Finishes, General: Prepare, pretreat, and apply coating to exposed metal surfaces to comply with coating and resin manufacturers' written instructions.
- B. Modified Silicone-Polyester Two-Coat System: 0.20 – 0.25 mil primer with 0.7 – 0.8 mil color coat[, meeting solar reflectance index requirements].
 - 1. Basis of Design: MBCI, Signature 200.

Specifier: MBCI's fluoropolymer coatings are based on Arkema, Inc. Kynar 500 and Solvay Solexis Hylar 500 PVF2 resins.

- C. Fluoropolymer Two-Coat System: 0.2 – 0.3 mil primer with 0.7 - 0.8 mil 70 percent PVDF fluoropolymer color coat, AAMA 621[, meeting solar reflectance index requirements].
 - 1. Basis of Design: MBCI, Signature 300.

SPECIFICATIONS

PART 3 - EXECUTION

3.1 EXAMINATION

- A. Examine metal panel system substrate with Installer present. Inspect for erection tolerances and other conditions that would adversely affect installation of metal panels.
 1. Inspect framing that will support insulated metal panels to determine if support components are installed as indicated on approved shop drawings and are within tolerances acceptable to metal panel manufacturer and installer. Confirm presence of acceptable framing members at recommended spacing to match installation requirements of metal panels.
- B. Correct out-of-tolerance work and other deficient conditions prior to proceeding with insulated metal panel installation.

3.2 METAL PANEL INSTALLATION

- A. Concealed-Fastener Formed Metal Panels: Install metal panel system in accordance with manufacturer's written instructions, approved shop drawings, project drawings, and referenced publications. Install metal panels in orientation, sizes, and locations indicated. Anchor panels and other components securely in place. Provide for thermal and structural movement.
- B. Fasten metal panels to supports with fasteners at each location indicated on approved shop drawings, at spacing and with fasteners recommended by manufacturer. Fasten panel to support structure through leading flange. Snap-fit back flange of subsequent panel into secured flange of previous panel.
 1. Cut panels in field where required using manufacturer's recommended methods.
 2. Dissimilar Materials: Where elements of metal panel system will come into contact with dissimilar materials, treat faces and edges in contact with dissimilar materials as recommended by metal panel manufacturer.
- C. Attach panel flashing trim pieces to supports using recommended fasteners and joint sealers.
- D. Joint Sealers: Install liquid sealants where indicated and where required for weatherproof performance of metal panel assemblies.
 1. Seal panel base assembly, openings, panel head joints, and perimeter joints using joint sealers indicated in manufacturer's instructions.
 2. Seal perimeter joints between window and door openings and adjacent panels using elastomeric joint sealer.
 3. Prepare joints and apply sealants per requirements of Division 07 Section "Joint Sealants."

3.3 ACCESSORY INSTALLATION

- A. General: Install metal panel accessories with positive anchorage to building and weather tight mounting; provide for thermal expansion. Coordinate installation with flashings and other components.
 1. Install components required for a complete metal panel assembly, including trim, copings, flashings, sealants, closure strips, and similar items.
 2. Comply with details of assemblies utilized to establish compliance with performance requirements and manufacturer's written installation instructions.
 3. Set units true to line and level as indicated. Install work with laps, joints, and seams that will be permanently weather resistant.

3.4 CLEANING AND PROTECTION

- A. Clean finished surfaces as recommended by metal panel manufacturer.
- B. Replace damaged panels and accessories that cannot be repaired to the satisfaction of the Architect.

END OF SECTION

DETAILS

PANEL ATTACHMENT

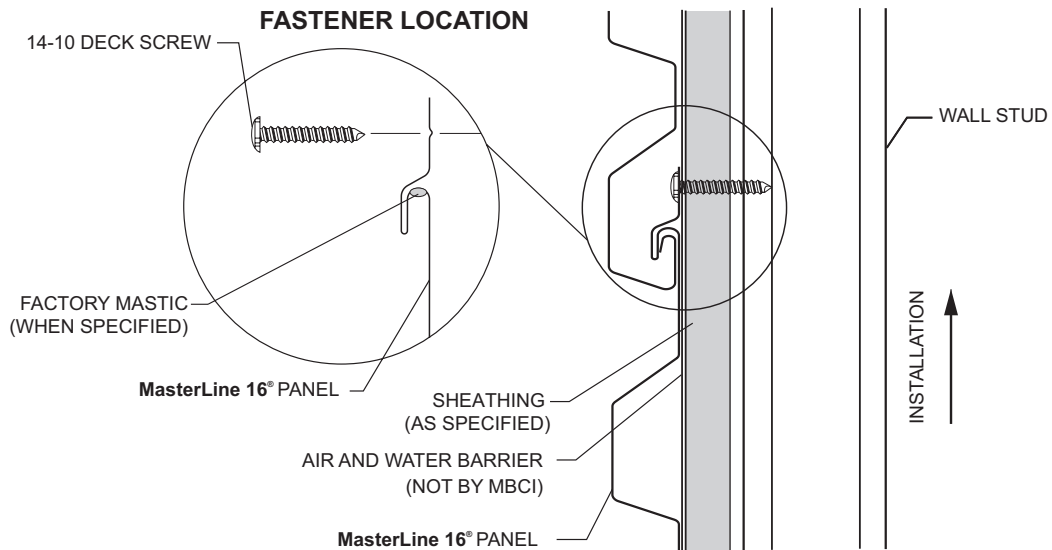
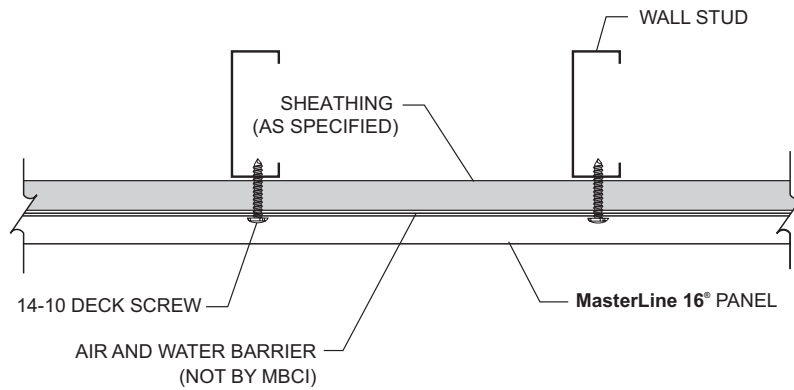

DETAILS

BASE DETAIL WITH ANGLE

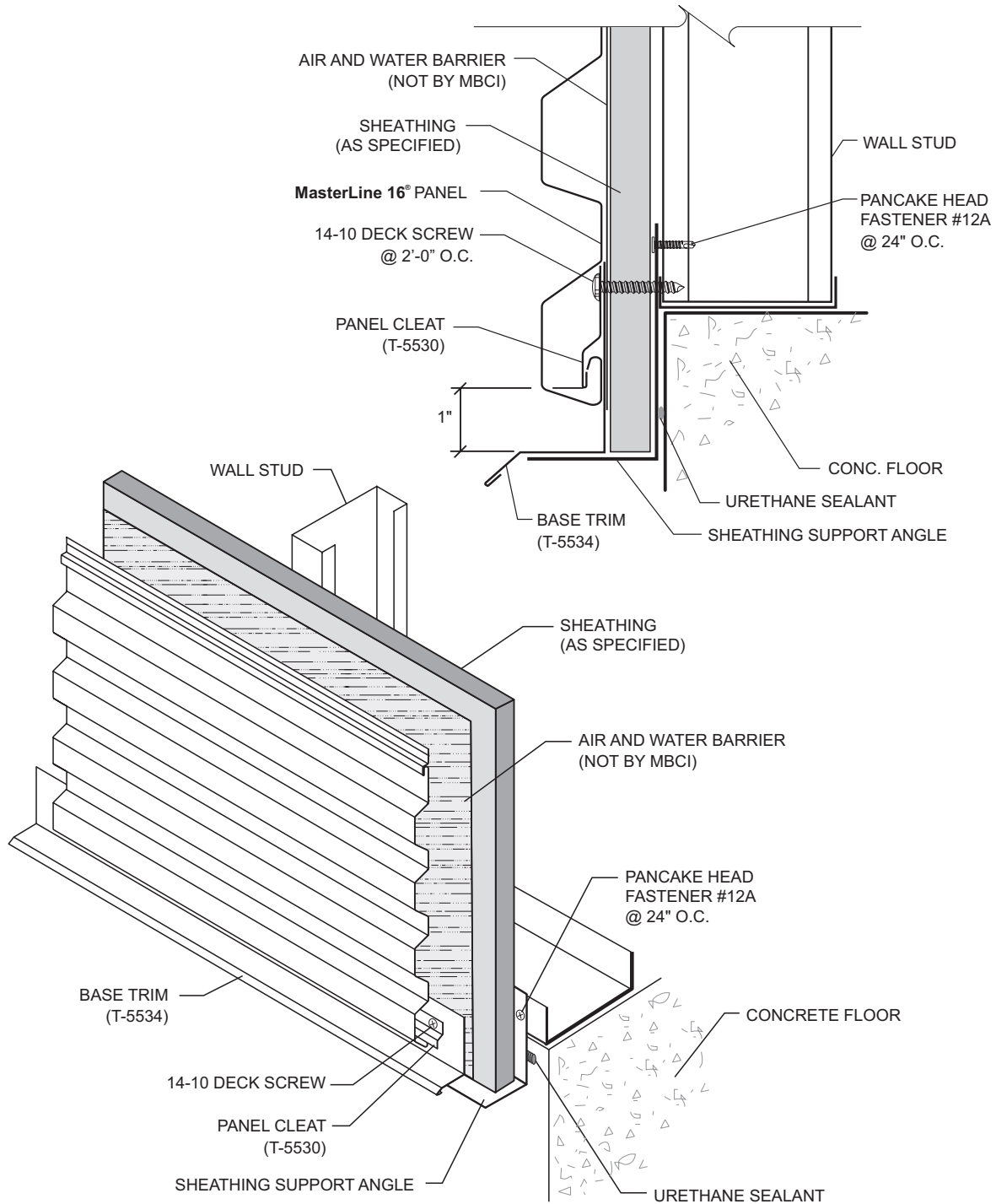

DETAILS

BASE DETAIL WITH SHEATHING NOTCH

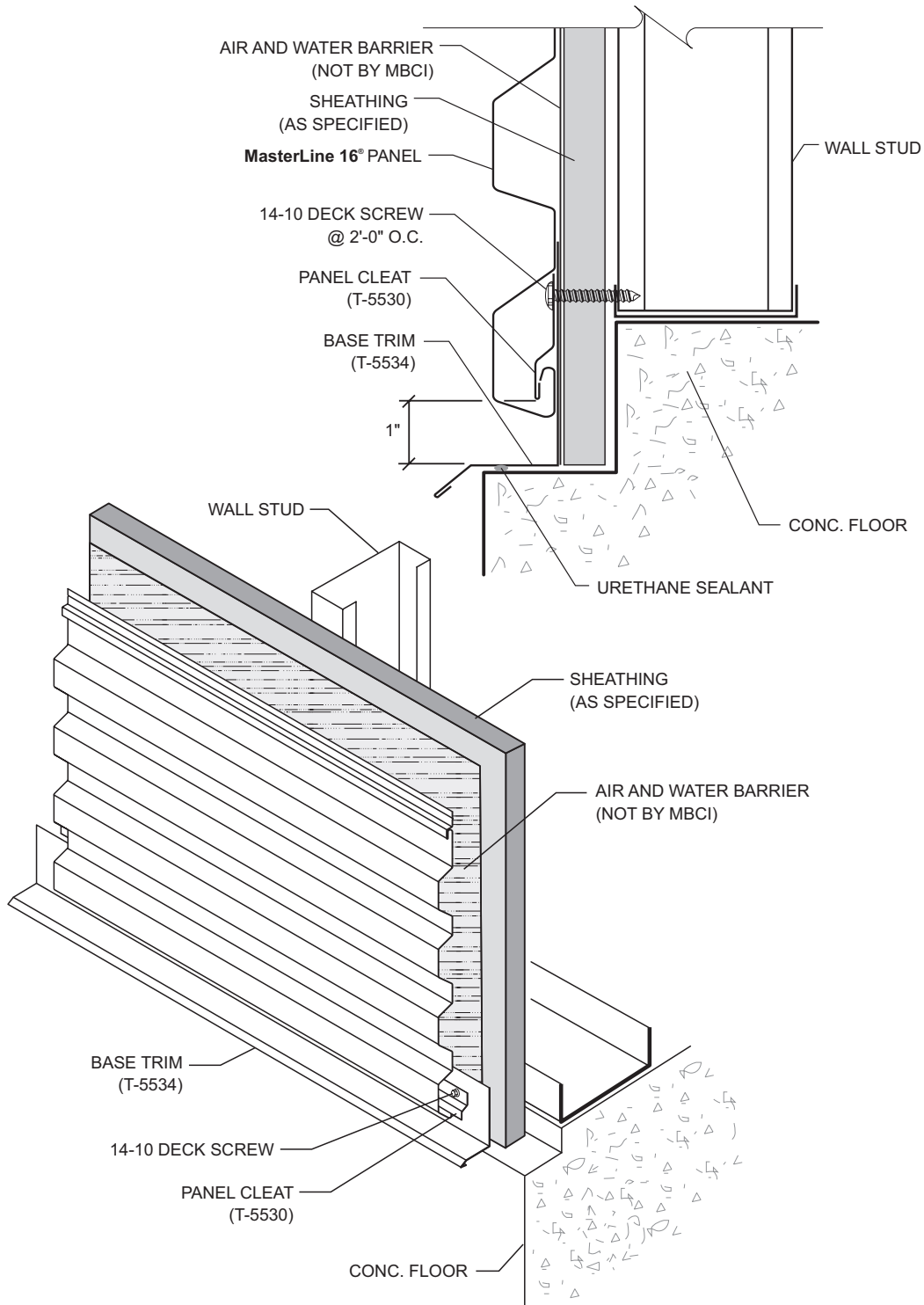

DETAILS

OUTSIDE CORNER DETAIL

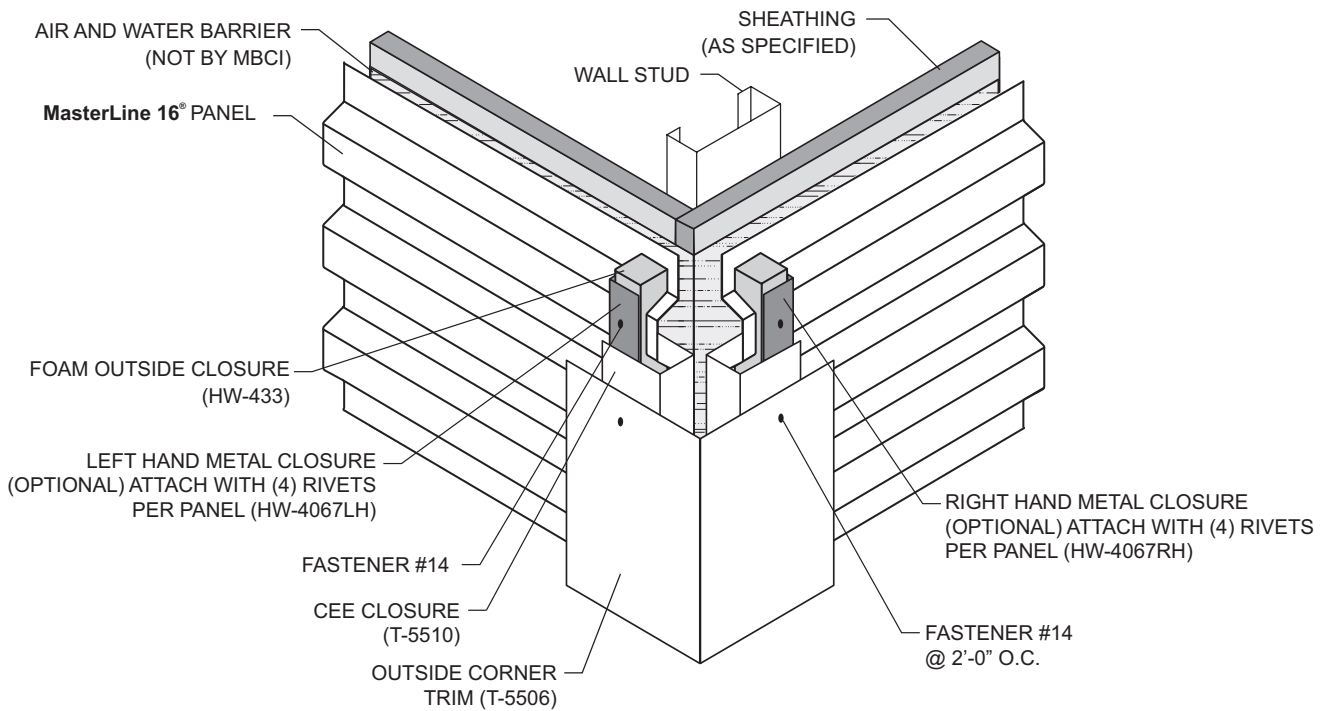
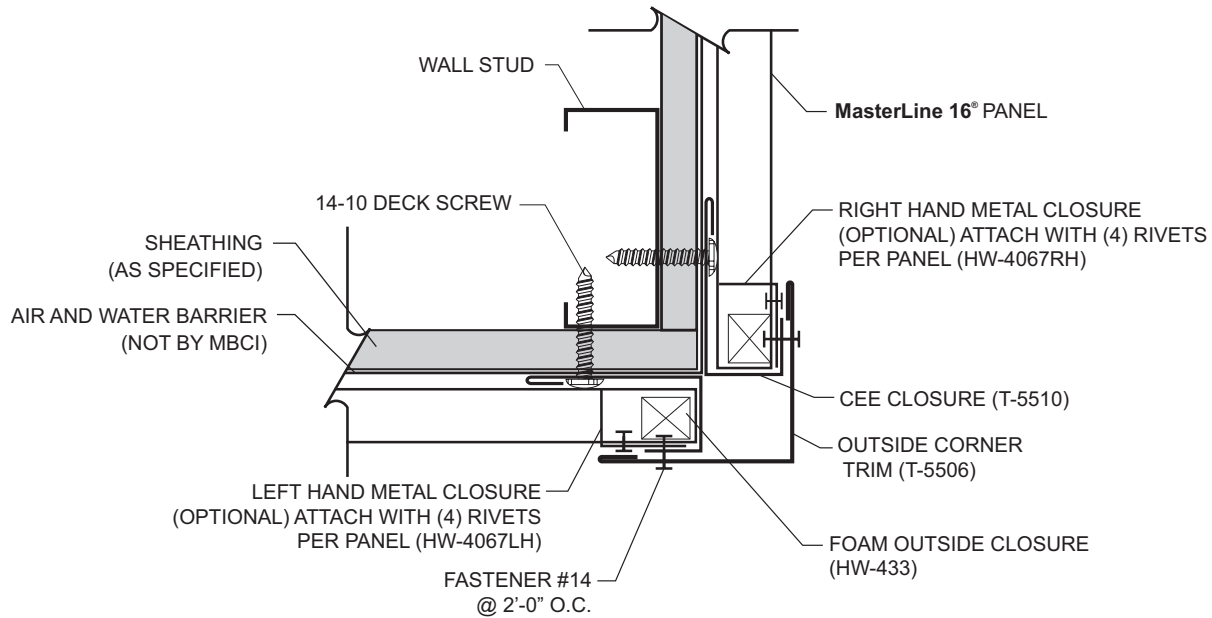

DETAILS

INSIDE CORNER DETAIL

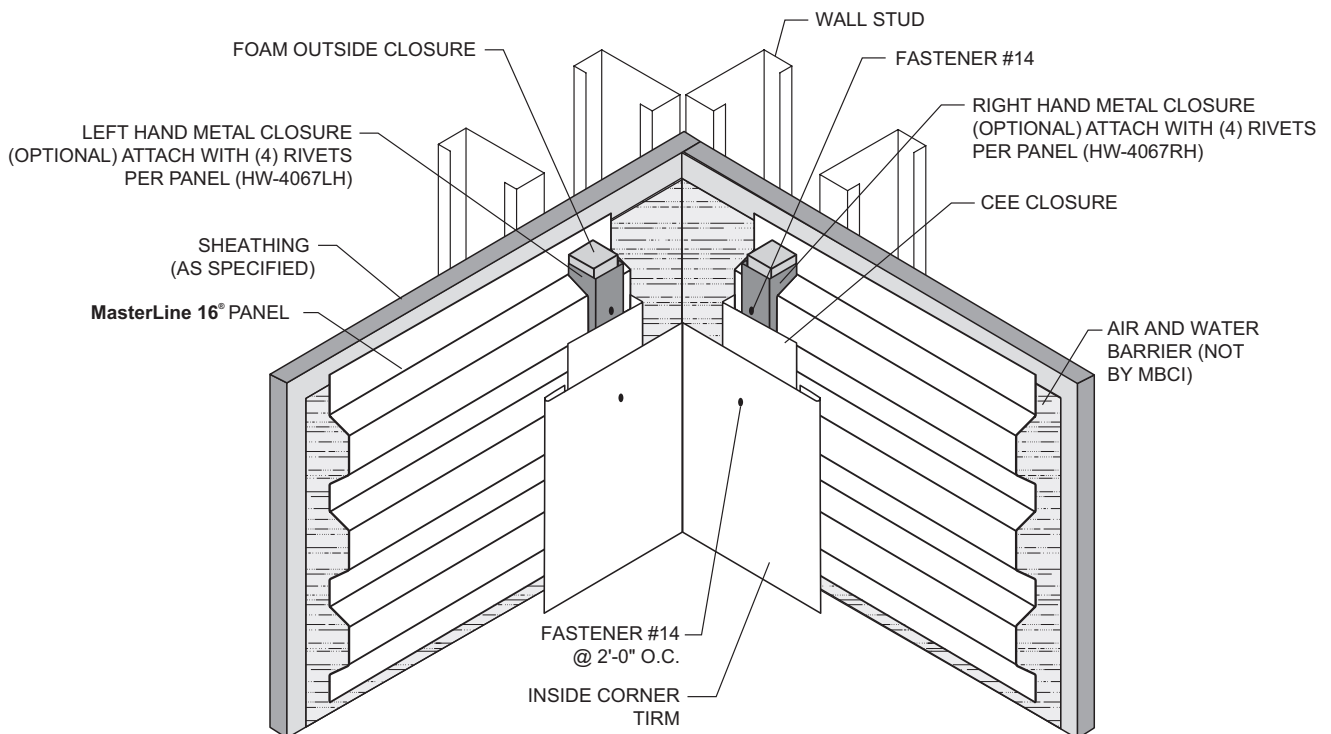
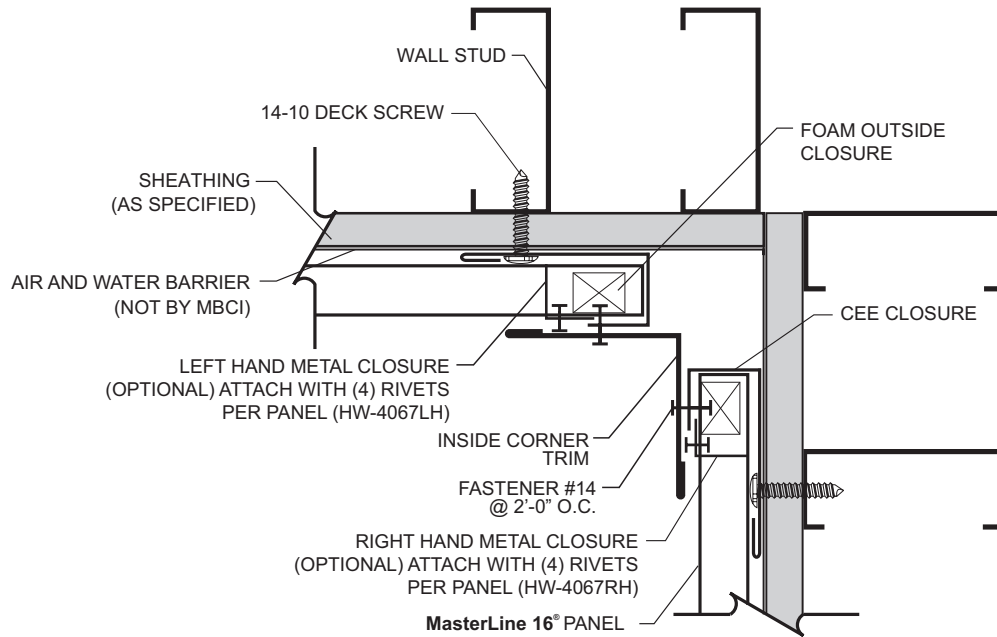

DETAILS

PARAPET DETAIL

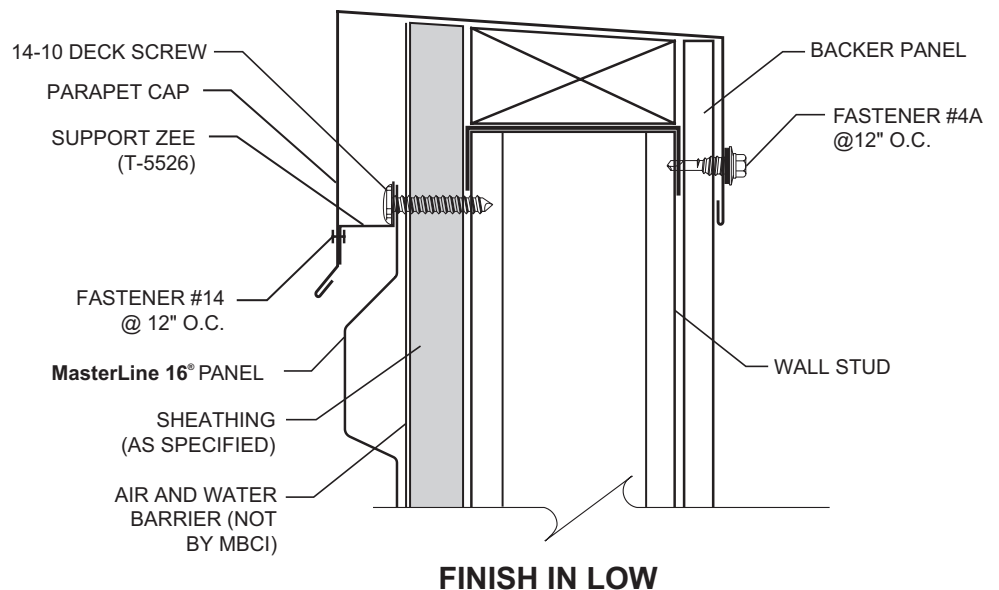
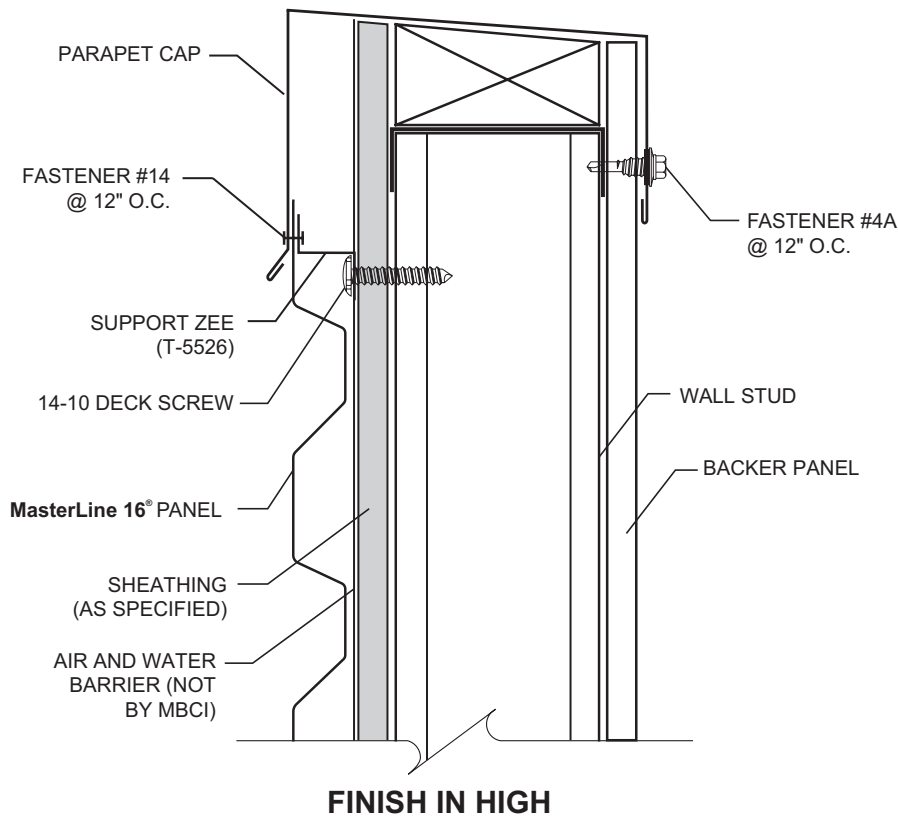

DETAILS

EAVE WITH BOX TRIM

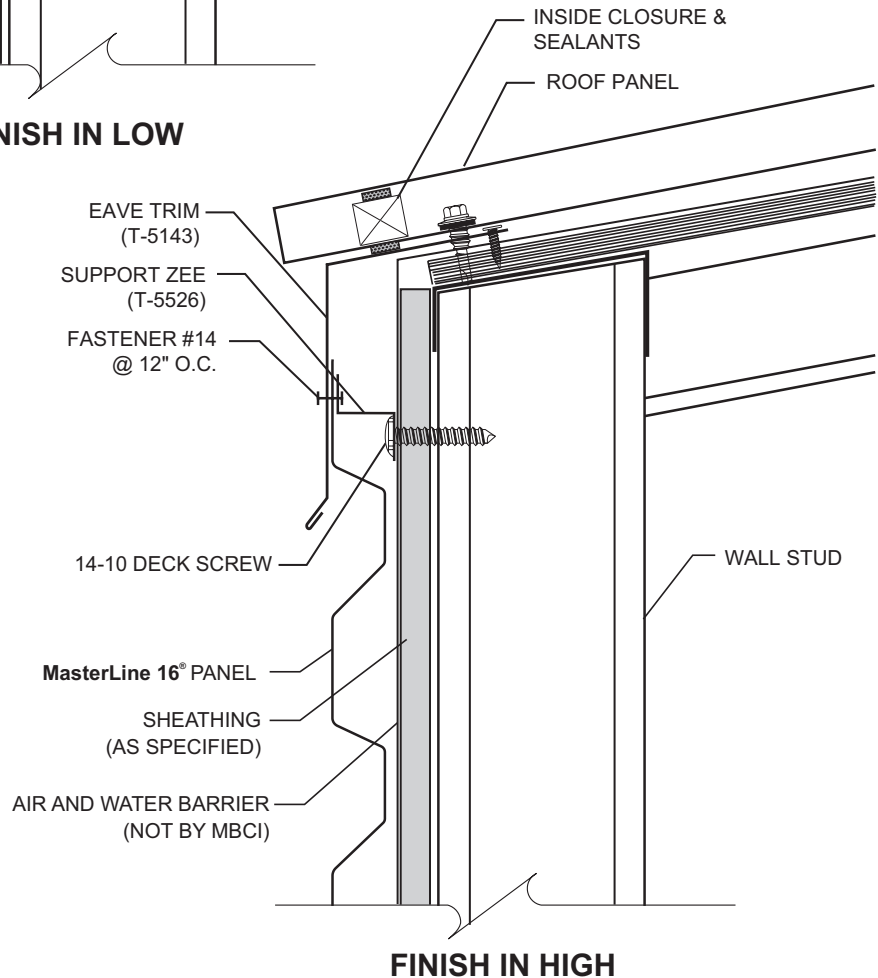
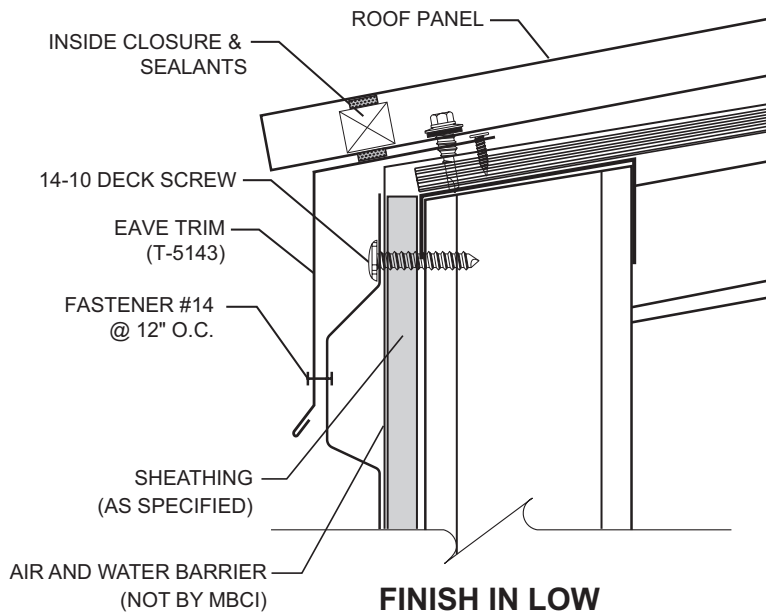

DETAILS

EAVE WITH BOX GUTTER

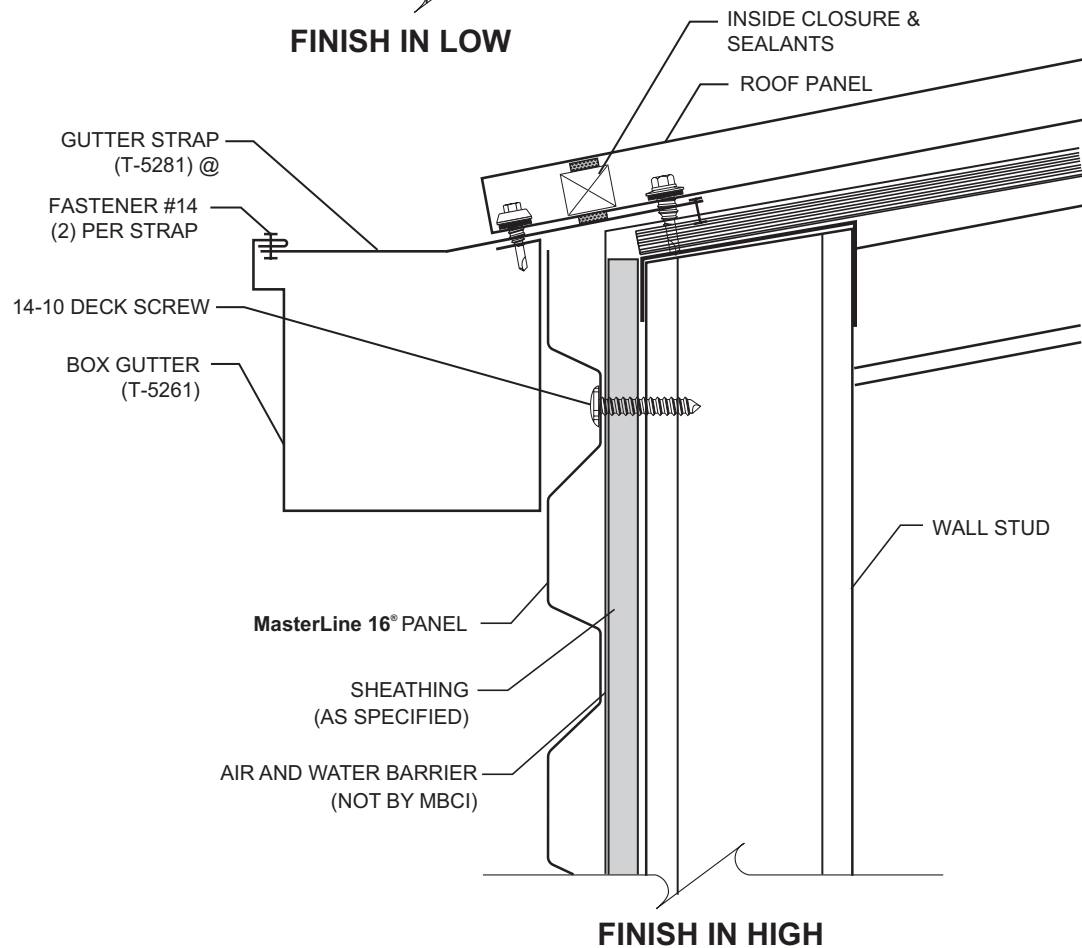
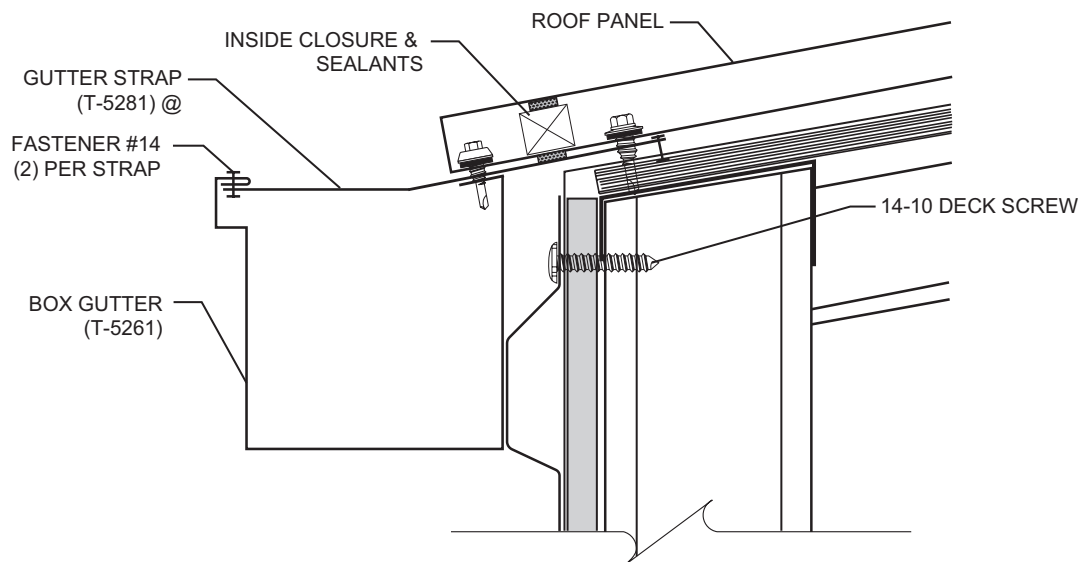

DETAILS

RAKE WITH BOX TRIM

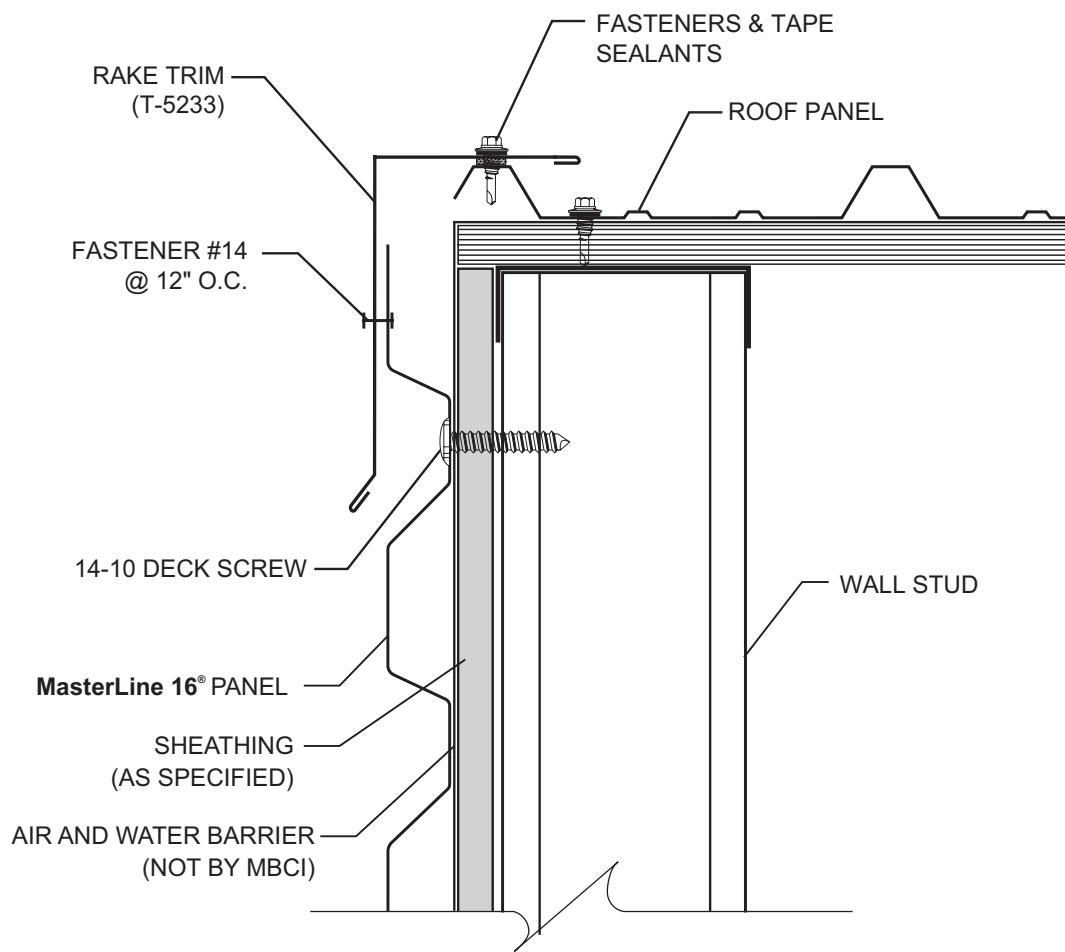

DETAILS

DOOR FRAMING DETAILS

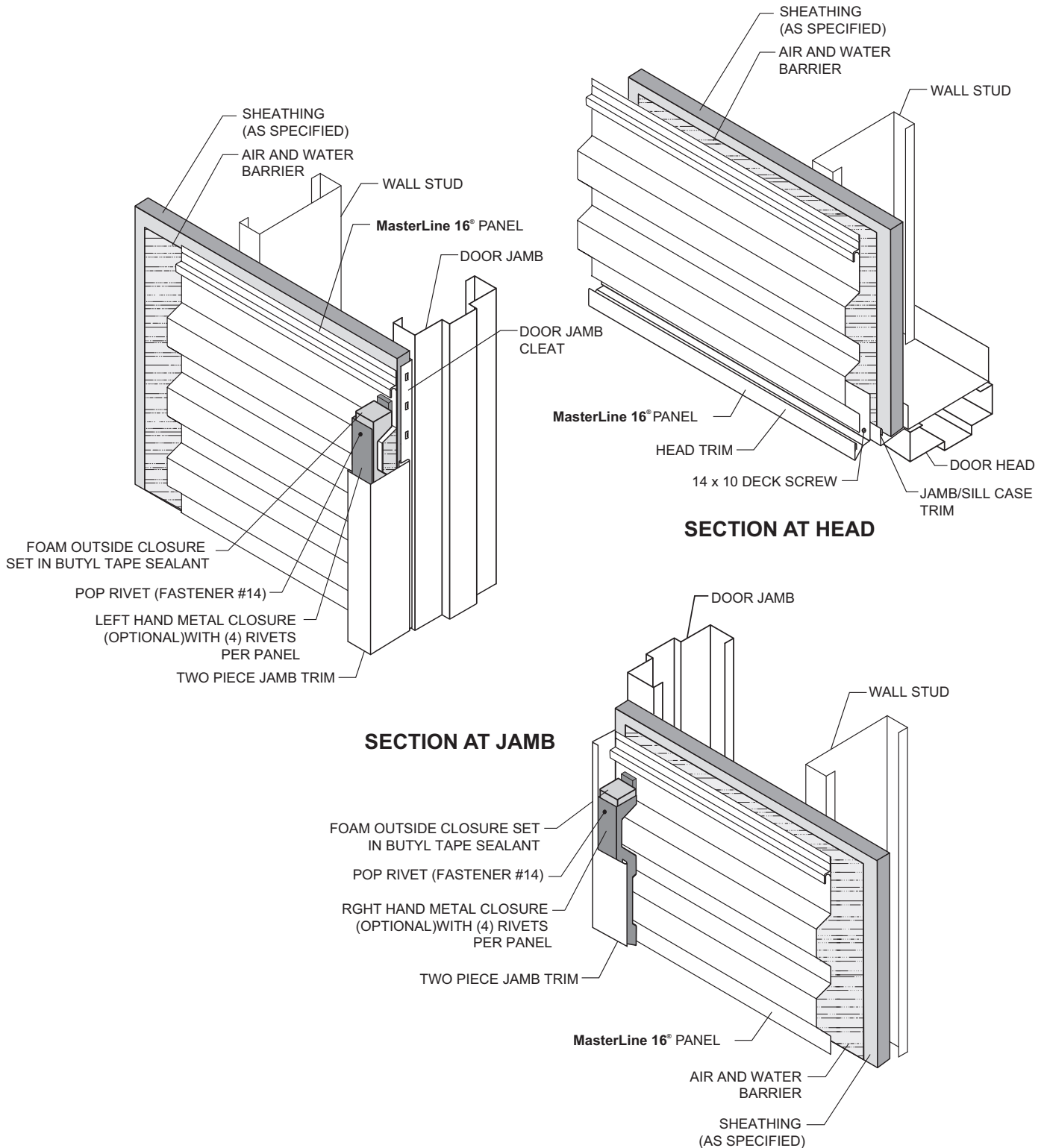

DETAILS

DOOR HEAD DETAIL

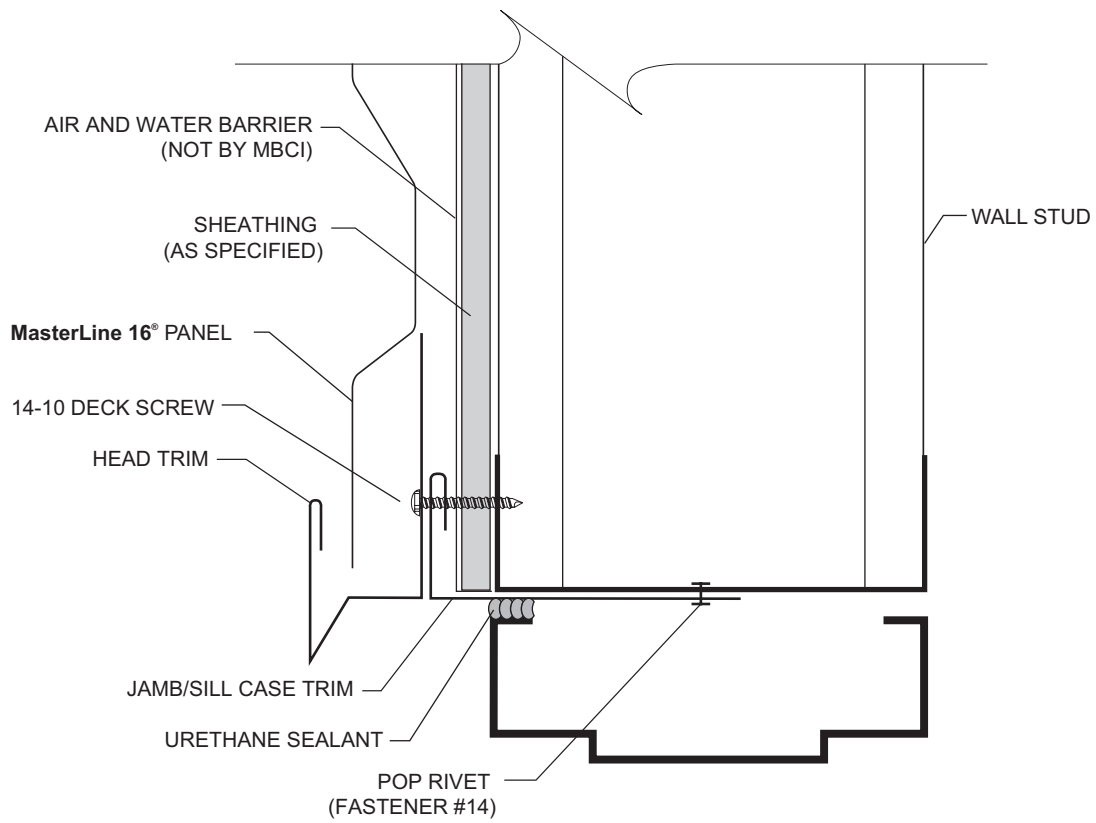

DETAILS

DOOR JAMB DETAIL

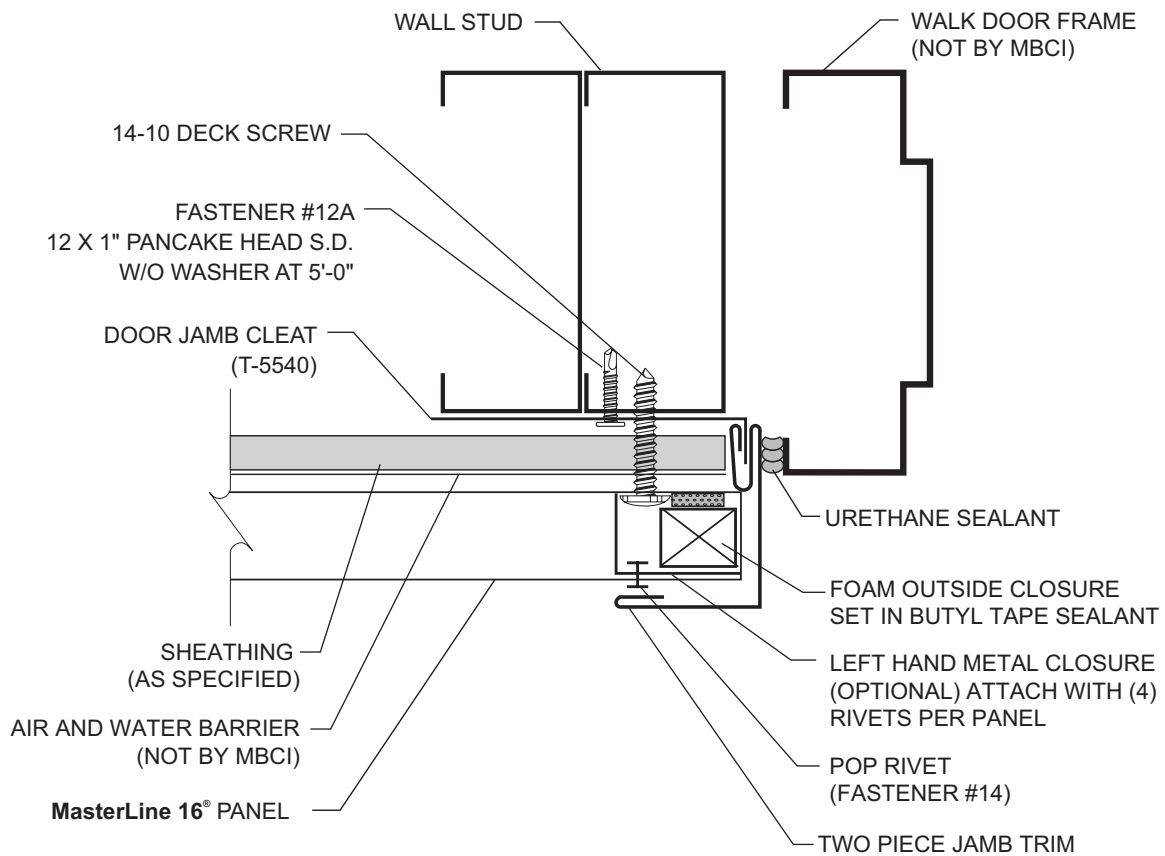

DETAILS

WINDOW FRAMING DETAILS

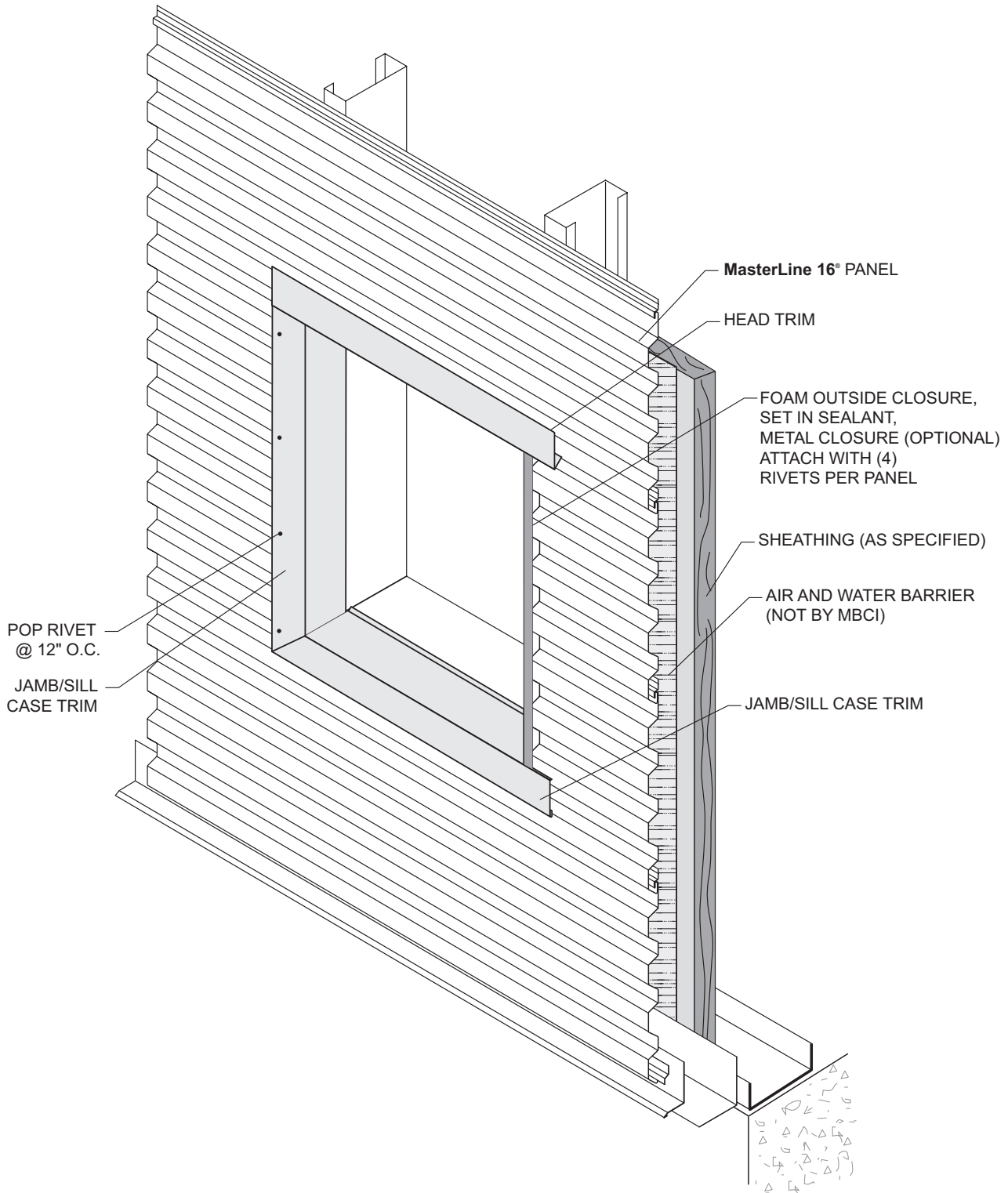

DETAILS

WINDOW SILL DETAILS

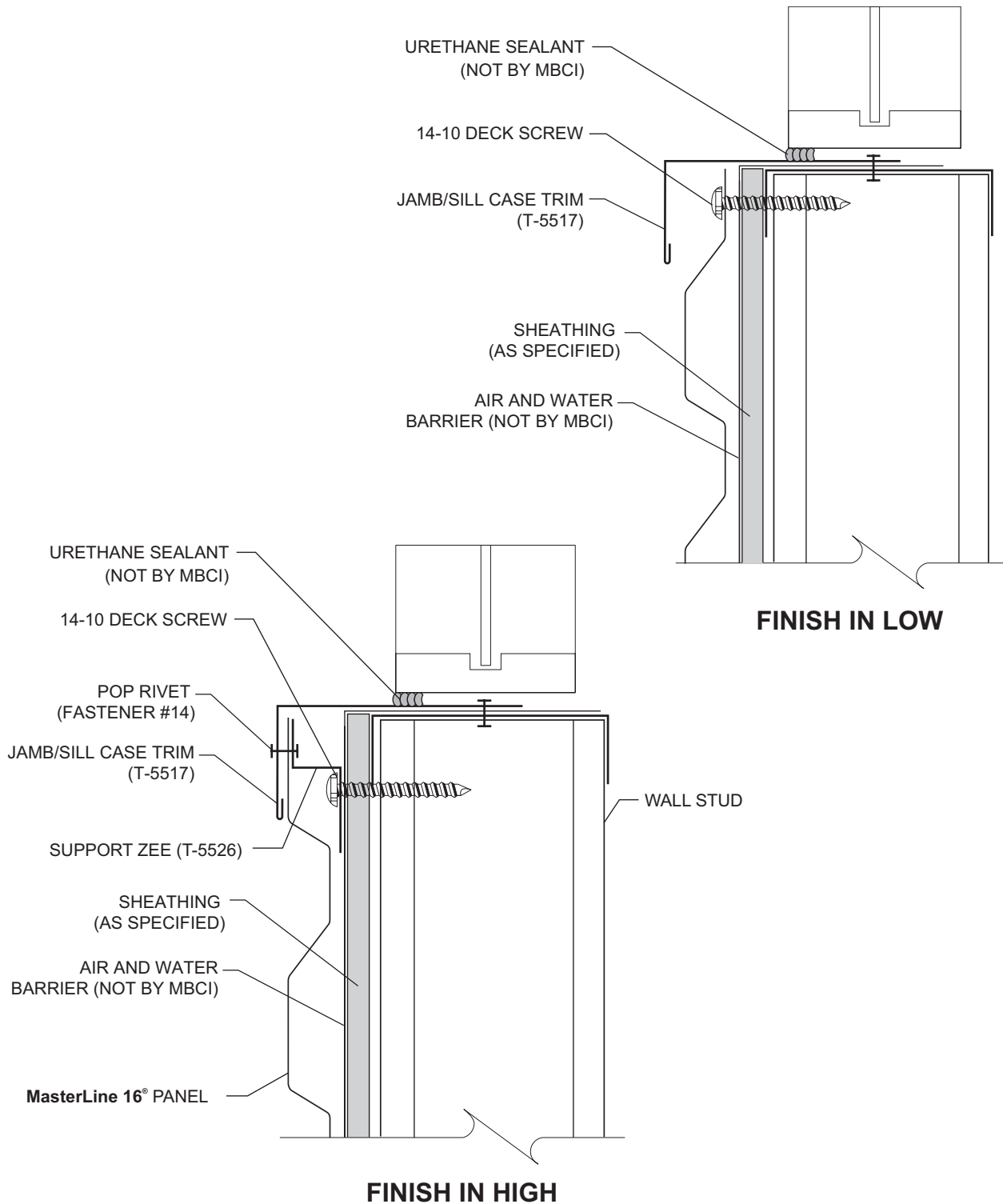

DETAILS

WINDOW JAMB DETAIL

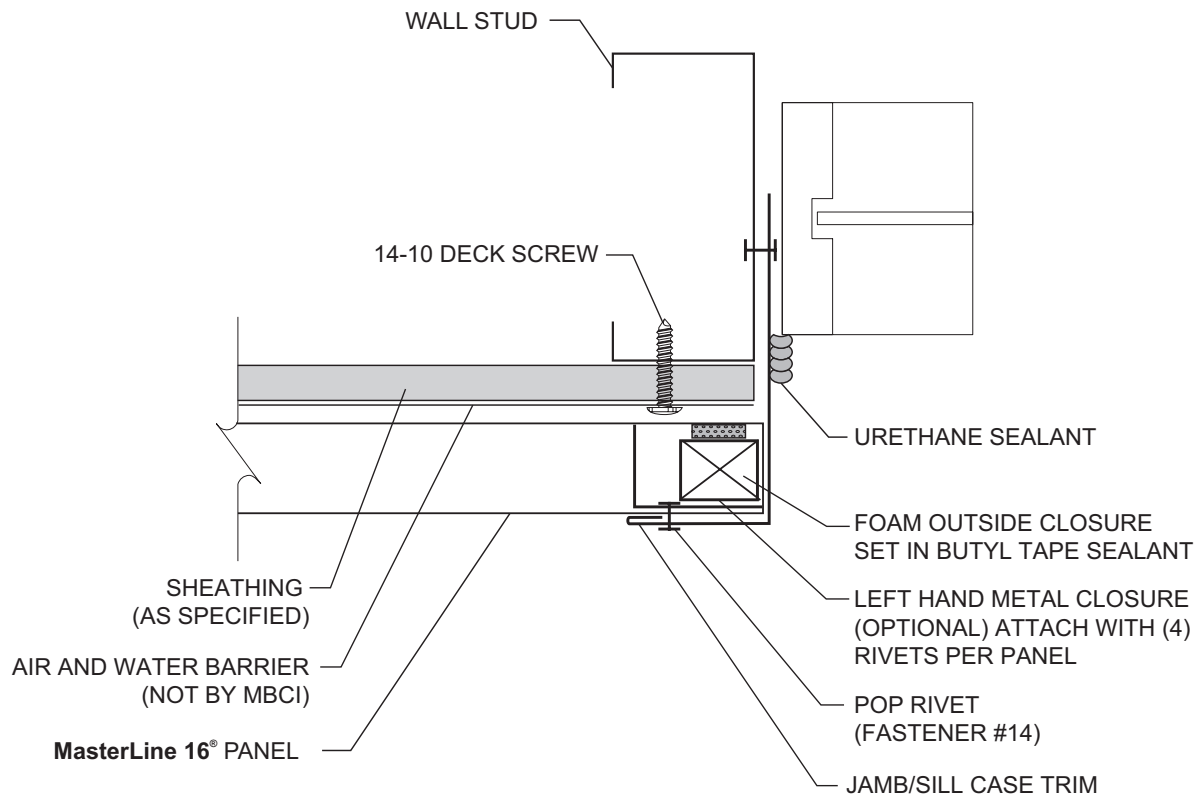

DETAILS

WINDOW HEAD DETAIL

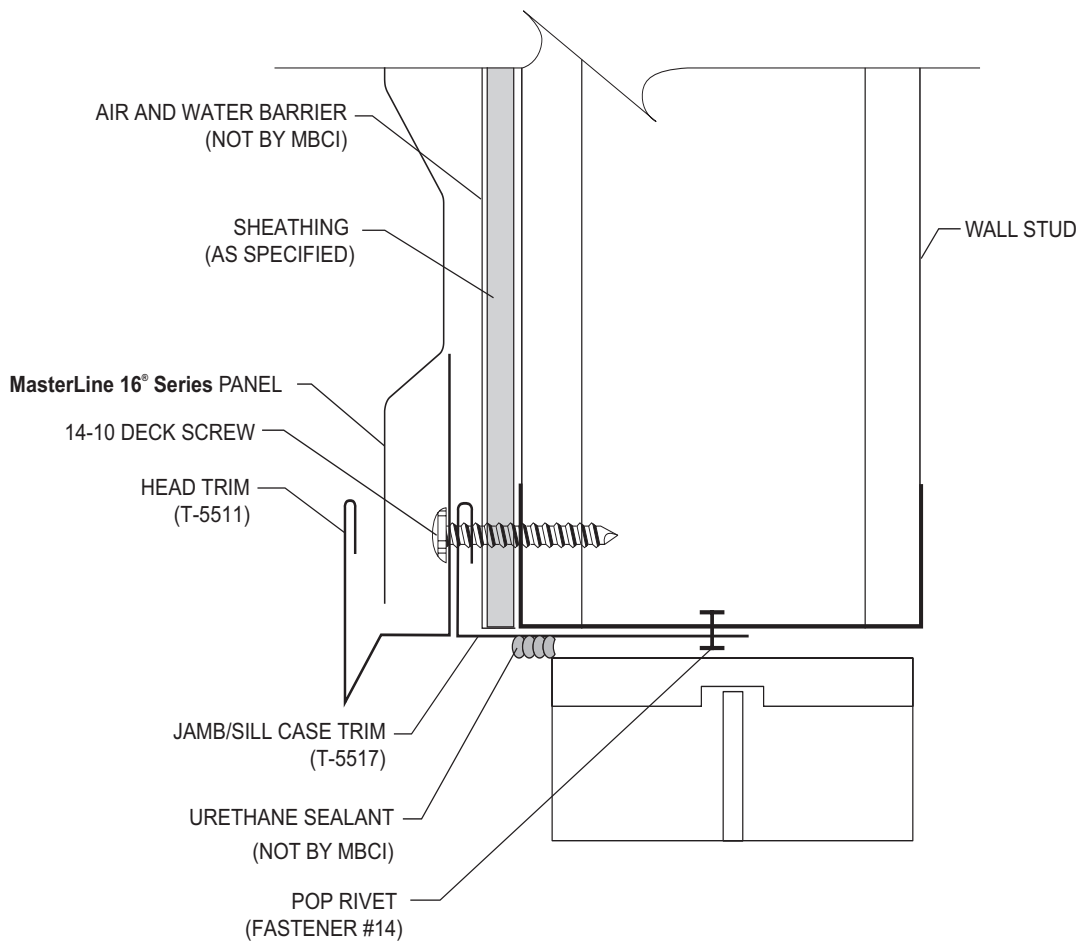

DETAILS

PANEL LAP

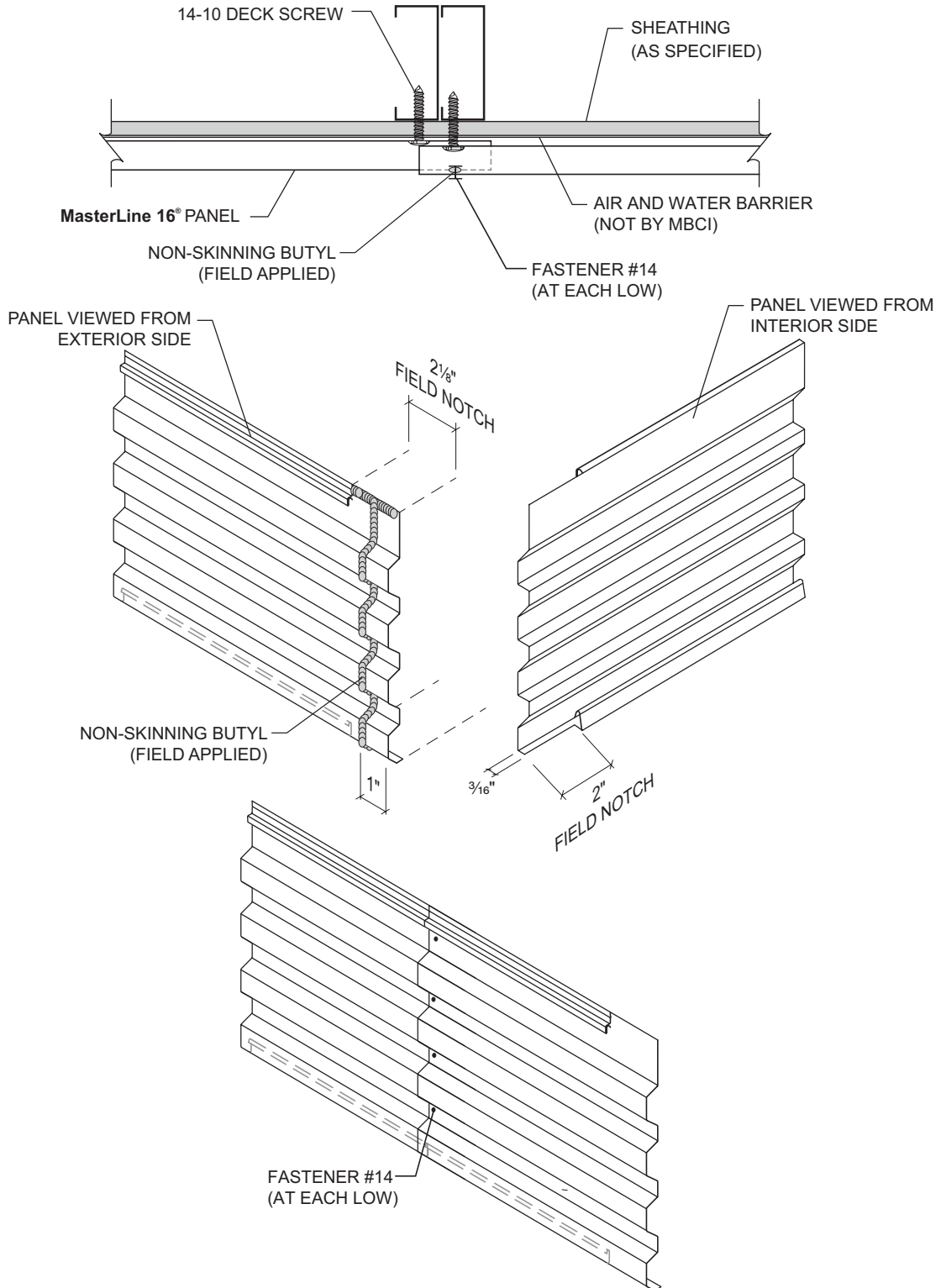

DETAILS

FLAT SPLICE TRIM

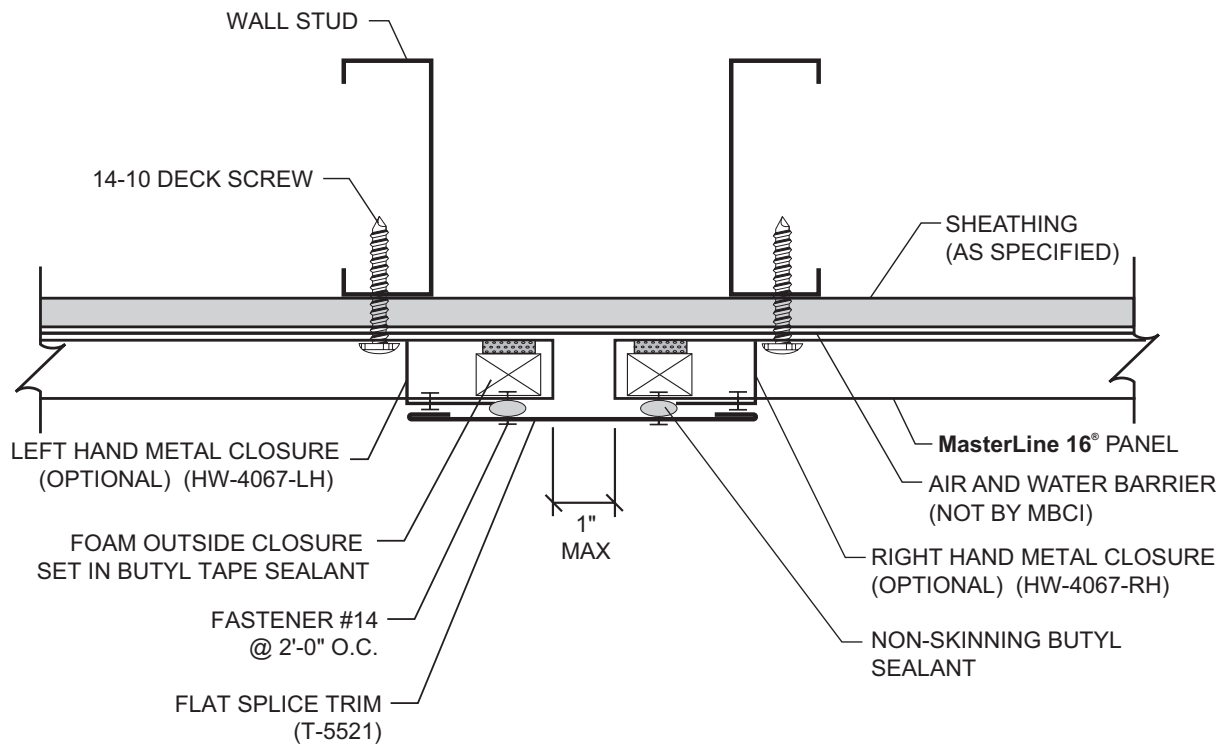

DETAILS

REVEAL SPLICE TRIM

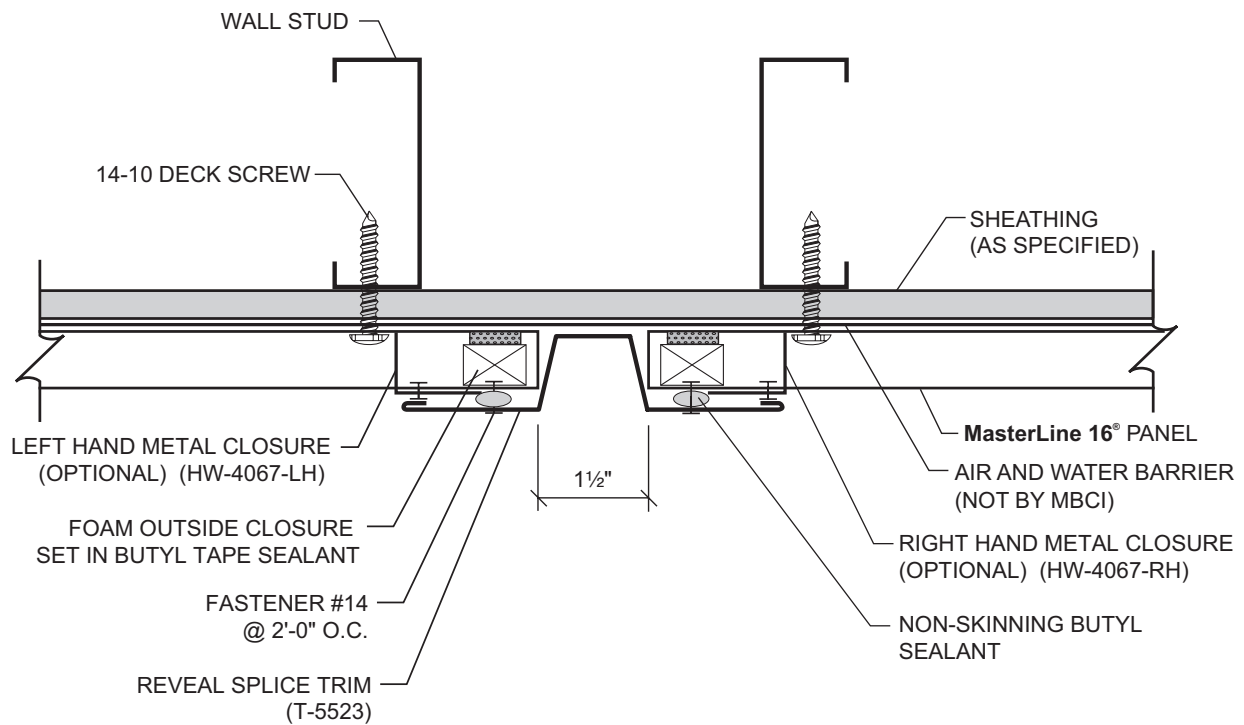

DETAILS

TERMINATION

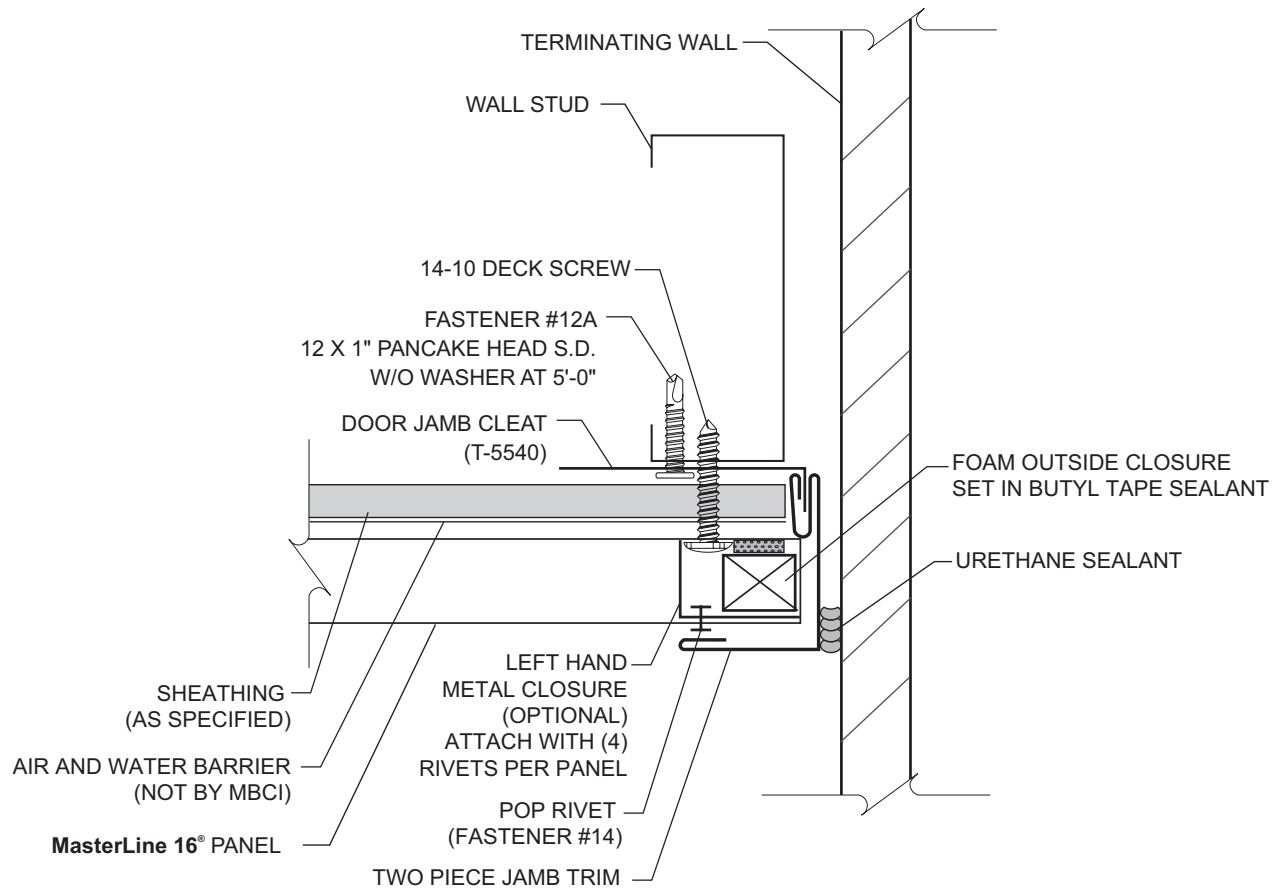



MasterLine 16[®]

NOTES

NOTES



Metal Roof and Wall Systems

For the most current information available, visit our Web site at www.mbc.com

Houston, TX
14031 West Hardy
P.O. Box 38217
Houston, TX 77238
281-407-6915

Adel, GA
1601 Rogers Road
P.O. Box 1107
Adel, GA 31620
888-514-6062

Atlanta, GA
2280 Monier Avenue
P.O. Box 44729
Atlanta, GA 30336
678-337-1619

Atwater, CA
550 Industry Way
P.O. Box 793
Atwater, CA 95301
209-445-3891

Indianapolis, IN
1780 McCall Drive
P.O. Box 657
Shelbyville, IN 46176
317-364-4329

Lubbock, TX
5711 East FM-40
P.O. Box 10133
Lubbock, TX 79408
806-224-2724

Memphis, TN
300 Highway 51 North
P.O. Box 366
Hernando, MS 38632
662-298-2337

Oklahoma City, OK
7000 S. Eastern Avenue
P.O. Box 95998
Oklahoma City, OK 73149
405-492-6968

Omaha, NE
1011 Ellison Avenue
Omaha, NE 68110
402-983-8006

Phoenix, AZ
660 South 91st Avenue
P.O. Box 739
Tolleson, AZ 85353
480-630-3022

Rome, NY
6168 State Route 233
P.O. Box 4141
Rome, NY 13442
315-371-4330

Salt Lake City, UT
1155 West 2300 North
P.O. Box 16027
Salt Lake City, UT 84116
385-715-2952

San Antonio, TX
8677 I-10 East
P.O. Box 69
Converse, TX 78109
210-888-9768

