



5V Crimp

Technical/Installation Information

IMPORTANT NOTICE

READ THIS MANUAL COMPLETELY PRIOR TO BEGINNING THE INSTALLATION OF THE 5V CRIMP PANEL SYSTEM. MBCI DETAILS MUST BE FOLLOWED AS A MINIMUM TO INSURE APPROPRIATE WARRANTIES WILL BE ISSUED.

ALWAYS INSPECT EACH AND EVERY PANEL AND ALL ACCESSORIES BEFORE INSTALLATION. NEVER INSTALL ANY PRODUCT IF ITS QUALITY IS IN QUESTION. NOTIFY MBCI IMMEDIATELY IF ANY PRODUCT IS BELIEVED TO BE OUT OF TOLERANCE, SPECIFICATION OR HAS BEEN DAMAGED DURING SHIPMENT.

IF THERE IS A CONFLICT BETWEEN PROJECT ERECTION DRAWINGS PROVIDED OR APPROVED BY THE MANUFACTURER AND DETAILS IN THIS MANUAL, PROJECT ERECTION DRAWINGS WILL TAKE PRECEDENCE.

© MBCI 2019, part of the Cornerstone Building Brands family.

The Engineering data contained herein is for the expressed use of customers and design professionals. Along with this data, it is recommended that the design professional have a copy of the most current version of the North American Specification for the Design of Cold-Formed Steel Structural Members published by the American Iron and Steel Institute to facilitate design. This Specification contains the design criteria for cold-formed steel components. Along with the Specification, the designer should reference the most current building code applicable to the project jobsite in order to determine environmental loads. If further information or guidance regarding cold-formed design practices is desired, please contact the manufacturer.

Descriptions and specifications contained herein were in effect at the time this publication was approved for printing. In a continuing effort to refine and improve products, MBCI reserves the right to discontinue products at any time or change specifications and/or designs without incurring obligation. To ensure you have the latest information available, please inquire or visit our website at www.mbc.com. Application details are for illustration purposes only and may not be appropriate for all environmental conditions, building designs, or panel profiles. Projects should be engineered to conform to applicable building codes, regulations, and accepted industry practices. Insulation is not shown in these details for clarity.

For complete performance specifications, product limitations, and disclaimers, please consult MBCI's Paint and Galvalume Plus® warranties. Upon receipt of payment in full, these warranties are available upon request for all painted or Galvalume Plus® prime products. Sample copies can be found at www.mbc.com or contact your local MBCI Sales Representative.

TABLE OF CONTENTS

PRODUCT INFORMATION

Architect/Engineer InformationV-2
General DescriptionV-3
UL 90 Construction NumbersV-4
Section PropertiesV-5
Product ChecklistV-6
Fastener PatternsV-7

DETAILS

RidgeV-8
EndlapV-9
ValleyV-10
HipV-11
RakeV-12
EaveV-13
GutterV-14
Slope ChangeV-15

PRODUCT INFORMATION

ARCHITECT/ENGINEER INFORMATION

1. Minimum recommended slope is 3:12. For slopes less than 3:12, call MBCI.
2. Use a properly aligned and uniform substructure to avoid panel distortion. Typical substructure - $\frac{5}{8}$ " plywood; alternate substructure metal or wood stringers. Spacing of stringers to be determined by load tables. For illustration purposes, details are shown over plywood.
3. 5V Crimp panels are water shedding panels and therefore must be installed on a minimum 3:12 roof slope. The panels must be installed over a completely waterproofed substructure. If the waterproof membrane is mechanically attached with metal fasteners of any type, fasteners should be covered to protect the back side of the roof panels. Any mechanical attachment device that does not lay flat on the deck will telegraph through the panels.
4. Panels are subject to surface distortion due to improperly applied fasteners. Overdriven fasteners will cause stress and induce oil canning across the panel at or near the point of attachment. Oil canning is not a cause for rejection.
5. For proper fastener application, see Product Checklist.
6. For continuous panels over 25', please inquire. Panels may be endlapped.
7. All panel ends must be sealed at eave and valley conditions. Refer to Pages V-11, V-14 and V-15 for end sealant details.
8. Fastener spacings across the width of the panel are shown on Page V-7. For fastener spacings along the length of the panel, use the wind load table on Page V-5 in conjunction with the governing code.

CAUTION

Most of the 5V Crimp load tables indicate panels can obtain a 20# live load on 2'-6" centers when installed over stringers. Please keep in mind these are uniform live loads and will not support a 200 pound man standing on one square foot. From an erectability and industry standard point of view, it is recommended that you should not span the panels more than 2'-6".

PRODUCT INFORMATION

GENERAL DESCRIPTION

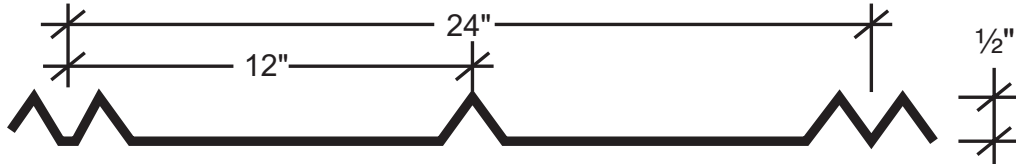

Coverage Width - 24"

Minimum Slope - 3:12

Panel Attachment - Wood screws

Panel Substrate - Galvalume Plus[®]

Gauges - 29 or 26

Finishes Smooth or Embossed

Coating - Signature 200[®] (Siliconized Polyester)

PRODUCT SELECTION CHART

Product	Galvalume Plus	Galvalume Plus	Signature 200
5V Crimp	29	26	26
24" Wide	●	●	●

● - Available in any quantity.

■ - Minimum quantity may be required.

PRODUCT INFORMATION

UL 90 Requirements 5V Crimp Construction # 453

1. Metal Panels (26 gauge) – 24"wide, continuous over two or more spans.
2. Fastener spacing along the length of the panel is 3 feet on center.
3. Fasteners – No.14-10 x 1½" Type A, Hex Head with separate ⅝ in. O.D. steel washer and a bonded neoprene washer. Fastener spacing is as follows: a line of fasteners is to be installed adjacent to the double "V" in the middle of the panel for a total of four fasteners across the width of the panel. Fastener spacing along the length of the panel is 3 feet on center.

FIRE RESISTANCE RATING

The panel qualifies for a Class A fire rating when installed over a non-combustible substrate in compliance with Underwriters Laboratories Standard UL-263. Panels installed over combustible substrate will qualify for a Class C Fire Rating only.

IMPACT RESISTANCE

The 5V panels carry a Class 4 rating under UL-2218 "Test Standard For Impact Resistance".

For UL 90 Rated Roofs, the above requirements must be followed. See UL Roofing Materials and Systems Directory for additional requirements. If you have any questions, call MBCI before proceeding.

State of Florida Approval Numbers: FL#11903.1

Miami Dade County NOA: 11-0810.10, see special installation instructions, www.miamidade.gov.

PRODUCT INFORMATION

5V CRIMP 24" Coverage

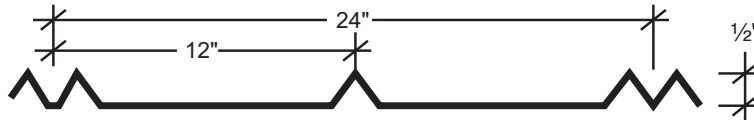

SECTION PROPERTIES								
			NEGATIVE BENDING			POSITIVE BENDING		
PANEL	F _y	WEIGHT	I _{xe}	S _{xe}	Maxo	I _{xe}	S _{xe}	Maxo
GAUGE	(KSI)	(PSF)	(IN.4/FT.)	(IN.3/FT.)	(KIP-IN.)	(IN.4/FT.)	(IN.3/FT.)	(KIP-IN.)
29	60 *	0.60	0.0011	0.0045	0.161	0.0022	0.0060	0.285
26	60 *	0.95	0.0016	0.0063	0.225	0.0030	0.0081	0.386

* F_y is 80-ksi reduced to 60-ksi in accordance with the 2012 edition of the North American Specification For Design Of Cold-Formed Steel Structural Members - A2.3.2.

Notes:

- All calculations for the properties of 5V Crimp panels are calculated in accordance with the 2012 edition of the North American Specification for the Design of Cold-Formed Steel Structural Members.
- I_{xe} is for deflection determination.
- S_{xe} is for bending.
- Maxo is allowable bending moment.
- All values are for one foot of panel width.

29 Gauge (0.0133"), F_y = 60 ksi, F_u = 61.5 ksi

SPAN TYPE	LOAD TYPE	SPAN IN FEET						
		1.0	1.5	2.0	2.5	3.0	3.5	4.0
1-span	NEGATIVE WIND LOAD	107.04	47.57	26.76	17.13	11.89	8.74	6.41
	LIVE LOAD/DEFLECTION	130.26	57.28	24.17	12.37	7.16	4.51	3.02
2-span	NEGATIVE WIND LOAD	162.81	78.38	45.49	29.56	20.70	15.29	11.74
	LIVE LOAD/DEFLECTION	101.37	46.40	26.38	16.97	11.82	8.70	6.67
3-span	NEGATIVE WIND LOAD	167.25	74.33	41.81	26.76	18.58	13.65	10.45
	LIVE LOAD/DEFLECTION	123.94	57.39	32.78	21.13	13.61	8.57	5.74
4-span	NEGATIVE WIND LOAD	173.39	77.06	43.35	27.74	19.27	14.15	10.84
	LIVE LOAD/DEFLECTION	116.57	53.77	30.66	19.75	13.76	9.10	6.09

26 Gauge (0.0181"), F_y = 60 ksi, F_u = 61.5 ksi

SPAN TYPE	LOAD TYPE	SPAN IN FEET						
		1.0	1.5	2.0	2.5	3.0	3.5	4.0
1-span	NEGATIVE WIND LOAD	150.26	66.78	37.57	24.04	16.70	12.27	9.39
	LIVE LOAD/DEFLECTION	224.74	77.61	32.74	16.76	9.70	6.11	4.09
2-span	NEGATIVE WIND LOAD	220.22	106.12	61.62	40.05	28.05	20.72	15.91
	LIVE LOAD/DEFLECTION	141.66	65.00	36.99	23.80	16.58	12.20	9.35
3-span	NEGATIVE WIND LOAD	234.79	104.35	58.70	37.57	26.09	19.17	14.67
	LIVE LOAD/DEFLECTION	172.89	80.32	45.93	29.63	18.33	11.54	7.73
4-span	NEGATIVE WIND LOAD	243.40	108.18	60.85	38.94	27.04	19.87	15.21
	LIVE LOAD/DEFLECTION	162.72	75.27	42.97	27.70	19.31	12.25	8.21

Notes:

- Strength calculations based on the 2012 AISI Standard "North American Specification for the Design of Cold-formed Steel Structural Members."
- Allowable loads are applicable for uniform loading and spans without overhangs.
- LIVE LOAD/DEFLECTION load capacities are for those loads that push the panel against its supports. The applicable limit states are flexure, shear, combined shear and flexure, web crippling at end and interior supports, and a deflection limit of L/180 under strength-level loads.
- NEGATIVE WIND LOAD capacities are for those loads that pull the panel away from its supports. The applicable limit states are flexure, shear, combined shear and flexure, and a deflection limit of L/60 under 10-year wind loading.
- Panel pullover and Screw pullout capacity must be checked separately using the screws employed for each particular application when utilizing this load chart.
- Effective yield strength has been determined in accordance with section A2.3.2 of the 2012 NAS specification.
- The use of any accessories other than those provided by the manufacturer may damage panels, void all warranties and will void all engineering data.
- This material is subject to change without notice. Please contact MBCI for most current data.

The Engineering data contained herein is for the expressed use of customers and design professionals. Along with this data, it is recommended that the design professional have a copy of the most current version of the North American Specification for the Design of Cold-Formed Steel Structural Members published by the American Iron and Steel Institute to facilitate design. This Specification contains the design criteria for cold-formed steel components. Along with the Specification, the designer should reference the most current building code applicable to the project jobsite in order to determine environmental loads. If further information or guidance regarding cold-formed design practices is desired, please contact the manufacturer.

PRODUCT INFORMATION

PRODUCT CHECKLIST

<p>5V Crimp Panel</p> <p><input type="checkbox"/> Specify Roof Pitch</p> <p>AG-202 <input type="checkbox"/></p>	<p>Ridge/Hip</p> <p><input type="checkbox"/> Specify Roof Pitch</p> <p>AG-202 <input type="checkbox"/></p>	<p>Valley</p> <p>Standard - For valley runs under 30'</p> <p>AG-237 <input type="checkbox"/></p> <p>Extended - For valley runs over 30'</p> <p>Specify Roof Pitch</p> <p>AG-239 <input type="checkbox"/></p>
<p>Rake Trim</p> <p>AG-250 <input type="checkbox"/></p>	<p>Drip Edge</p> <p>AG-279 <input type="checkbox"/></p>	<p>Box Gutter</p> <p>Specify Roof Pitch</p> <p>AG-242 <input type="checkbox"/></p>
<p>Eave Trim</p> <p>AG-246 <input type="checkbox"/></p>	<p>Outside Closure</p> <p>HW-452 <input type="checkbox"/></p> <p>Inside Closure</p> <p>HW-450 <input type="checkbox"/></p>	<p>Tri-Bead Tape Sealer</p> <p>HW-504 <input type="checkbox"/></p> <p>Triple Bead Tape Sealer</p> <p>HW-502 <input type="checkbox"/></p>
<p>Continuous Cleat</p> <p>FL-338 <input type="checkbox"/></p> <p>Zee Closure</p> <p>AG-274 <input type="checkbox"/></p>	<p>Urethane Tube Sealant</p> <p>White HW-540 <input type="checkbox"/></p>	<p>Fastener #9 10 x 1 1/2" Long Life Wood Fastener <input type="checkbox"/></p> <p>Fastener #13 10 x 1" Pancake Head <input type="checkbox"/></p> <p>Fastener #4 14 x 7/8" Long Life Lap Tek <input type="checkbox"/></p> <p>Fastener #14 1/8 x 3/16" Pop Rivet Stainless Steel <input type="checkbox"/></p>

PRODUCT INFORMATION

FASTENER PATTERNS

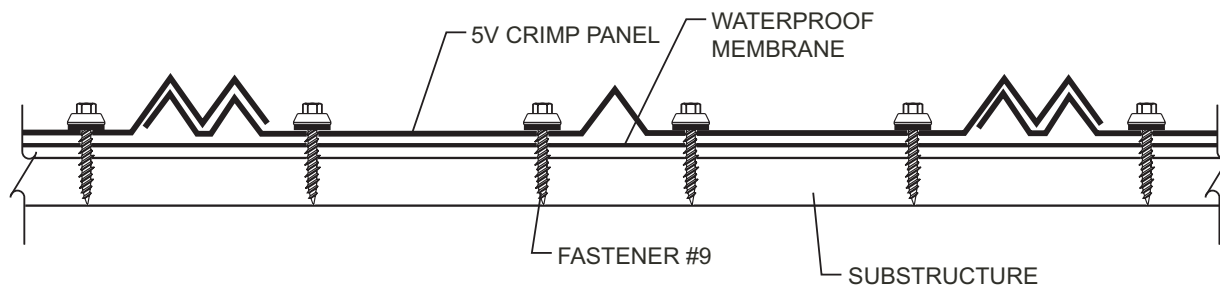

FASTENER PATTERN AT EAVE AND ENDLAP

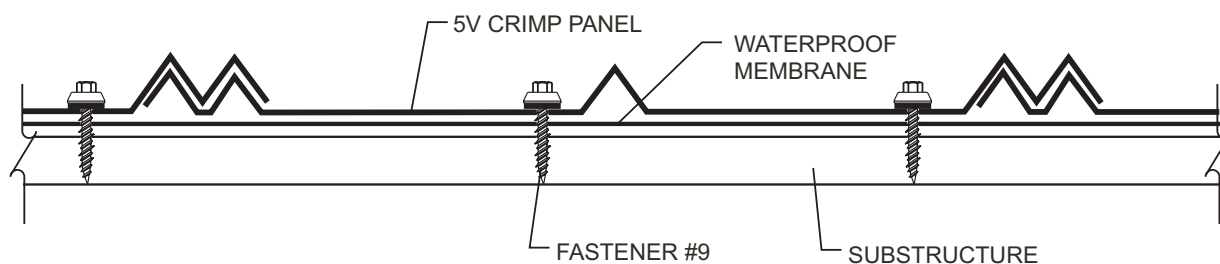

FASTENER PATTERN AT INTERIOR OF PANEL

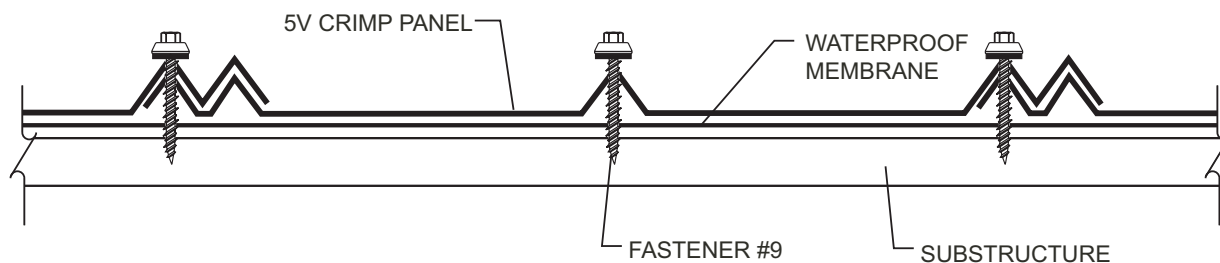

ALTERNATE FASTENER PATTERN

DETAILS

TYPICAL DETAILS RIDGE

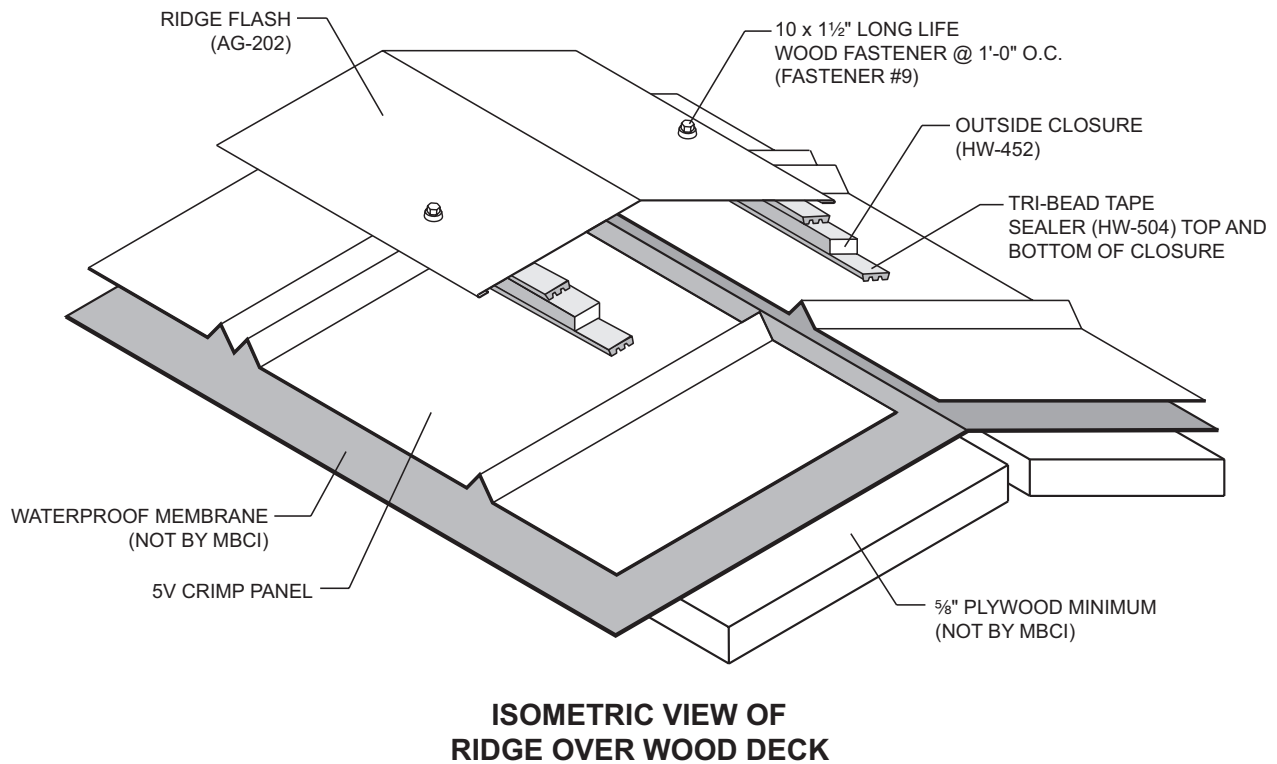
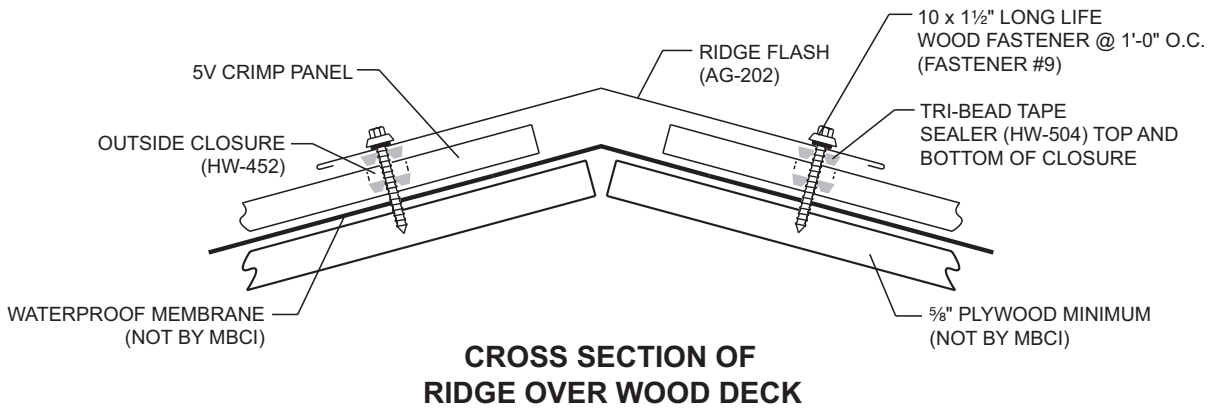

NOTE:

1. Stop panels 2" from center line of ridge.
2. Install first row of fasteners across panel to substrate 1'-0" down from bottom edge of ridge trim and space 1'-0" O.C.
3. Install Tri-Bead tape sealer across width of panels. Top edge of tape sealer is 1 3/4" from top edge of panel. Install outside closures on top of Tri-Bead tape sealer. Install additional run of tape sealer on top of outside closure.
4. Attach ridge flash with Fastener #9 (10 x 1 1/2" Long Life Wood Fastener) 1'-0" O.C. Install fasteners at each "V" in the panel to avoid dimpling the ridge flash.

DETAILS

TYPICAL DETAILS ENDLAP

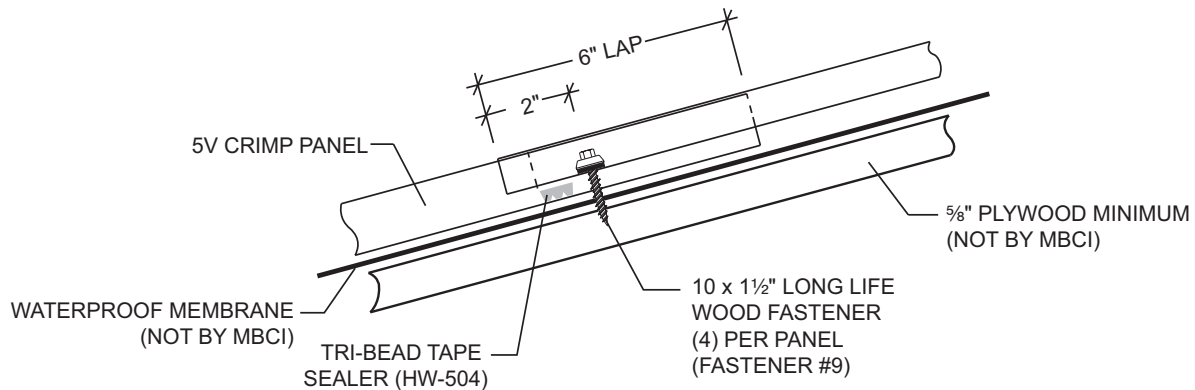

CROSS SECTION OF ENDLAP OVER WOOD DECK

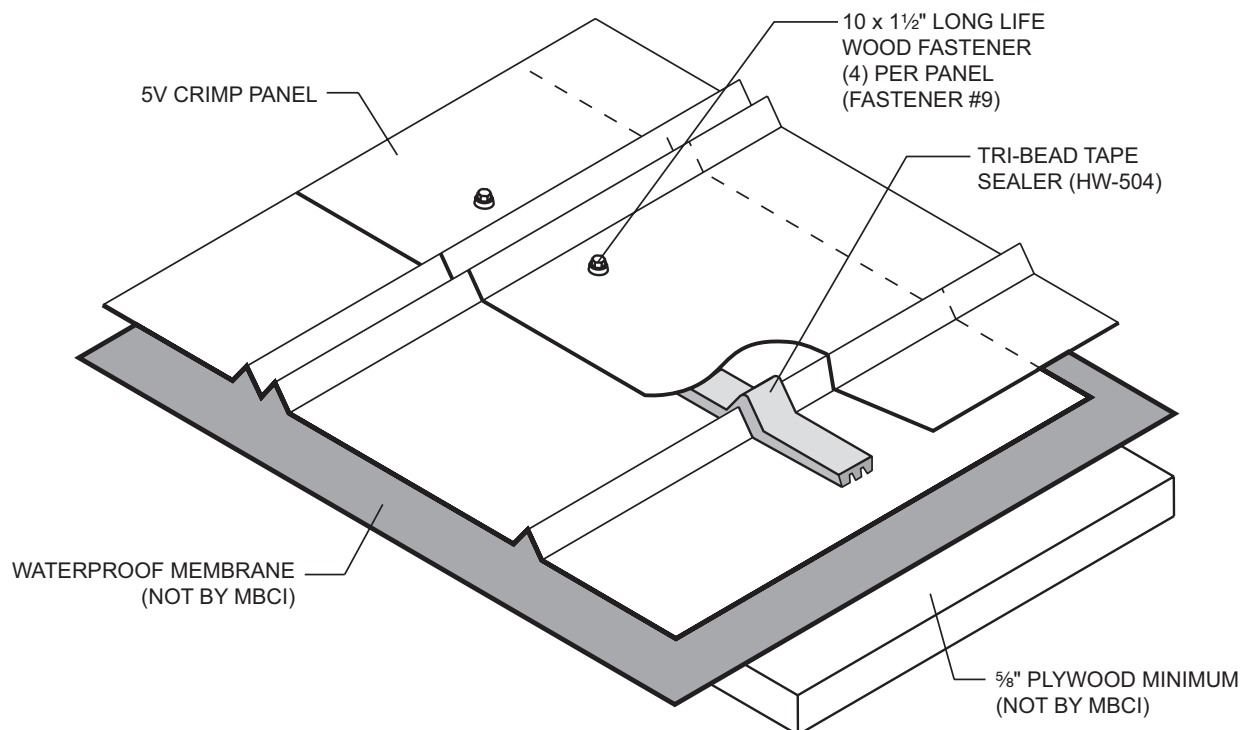

ISOMETRIC VIEW OF ENDLAP OVER WOOD DECK

NOTE:

1. Panel endlap is 6".
2. Install Tri-Bead tape sealer across width of bottom panel before installation of top panel. Top edge of tape sealer is 4/4" from upslope end of bottom panel.
3. Fastener pattern at endlap is shown on page V-7.

DETAILS

TYPICAL DETAILS VALLEY

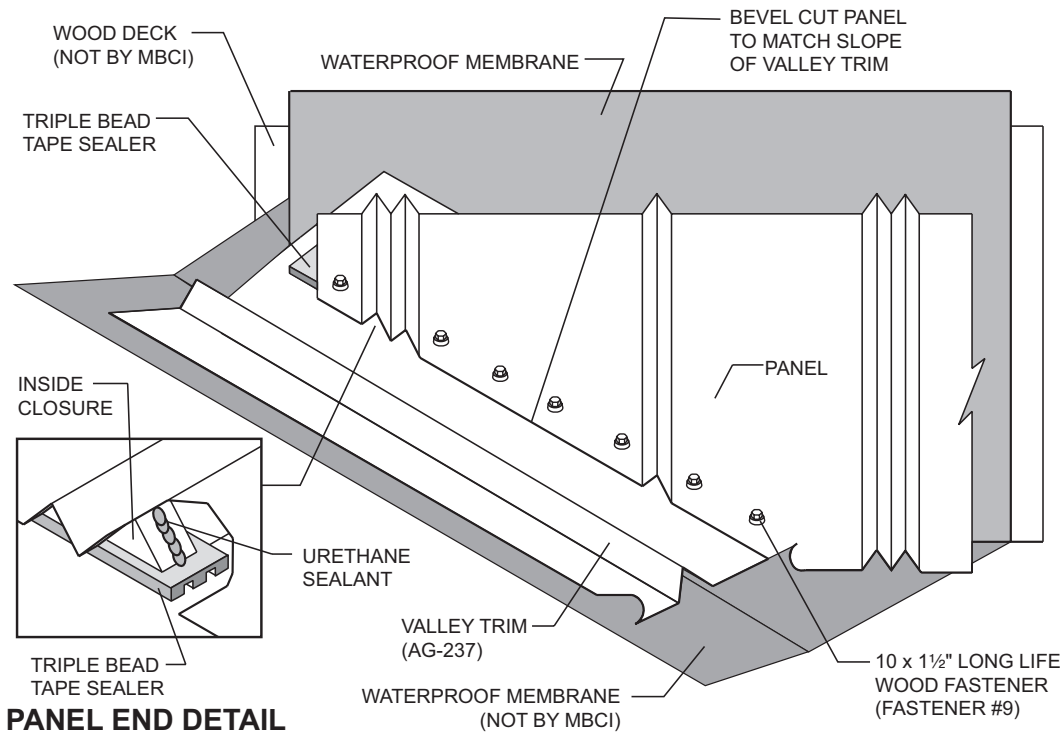
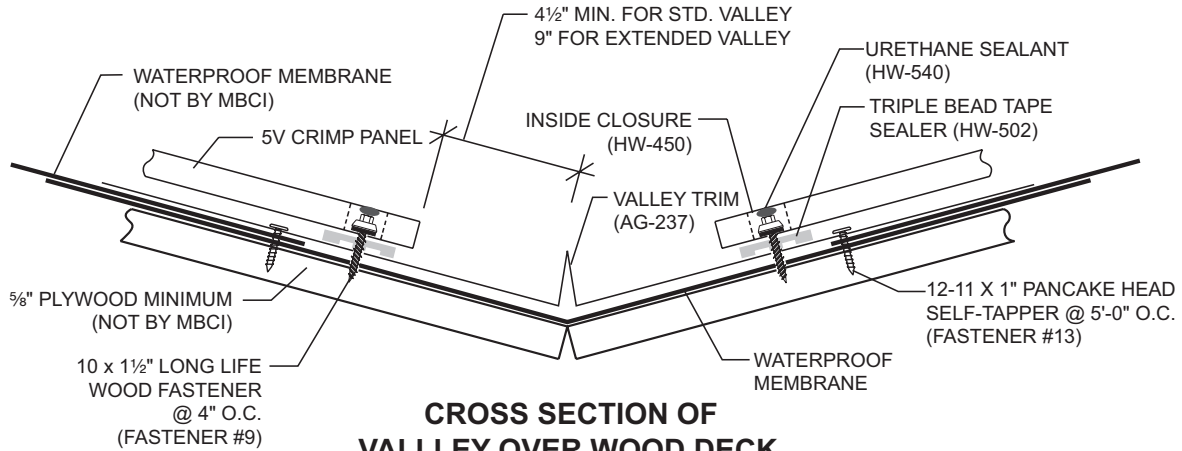

NOTE:

1. For valleys 30' or less in length, use standard valley trim. Valleys longer than 30' require extended valley trim.
2. Use waterproof membrane as a waterproof membrane in the valley area.
3. Apply Triple bead tape sealer to valley trim parallel to slope. Bottom edge of tape sealer is 1" from end of panel.
4. Bevel cut panel to match slope of valley trim.
5. Cut "V" from inside closure. Install "V" under panel and ontop of Triple bead tape sealer. Install a bed of urethane sealant to top of "V".
6. Fasten panel at valley with Fastener #9 (10 x 1½" Long Life Wood Fastener) 4" O.C. maximum.

DETAILS

TYPICAL DETAILS HIP

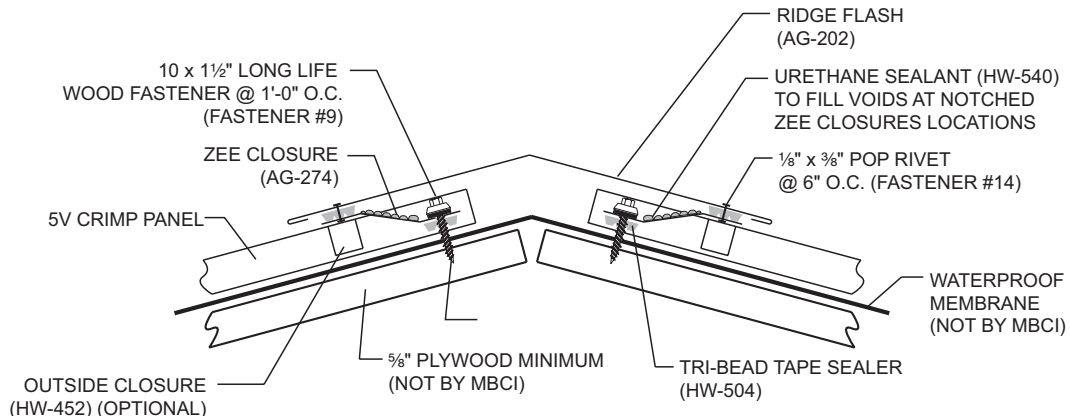

CROSS SECTION OF HIP

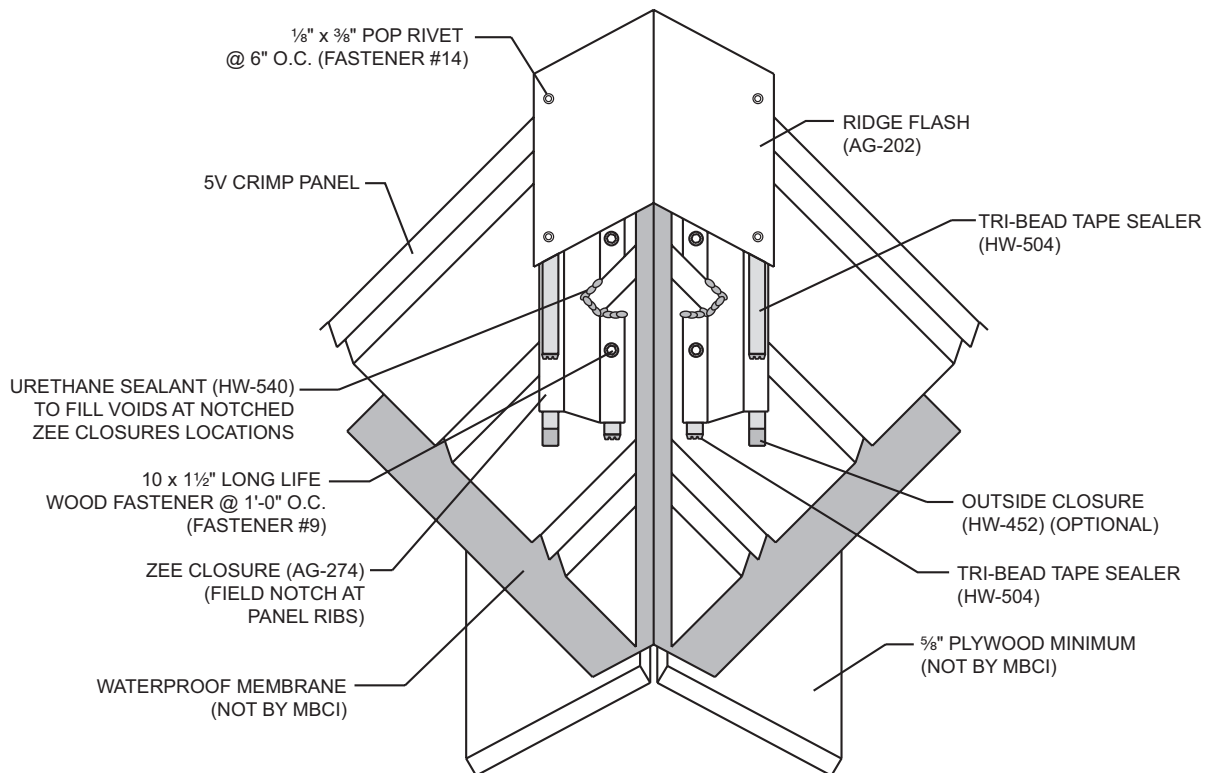

ISOMETRIC VIEW OF HIP

NOTE:

1. Bevel cut panels to match slope of hip and install.
2. Install Tri-Bead tape sealer across panels parallel to slope of hip. Top edge of tape sealer is 1½" center of hip.
3. Notch bottom flange and web of Zee closure at each "V" of the panel. Install Zee closure with Fastener #9 (10 x 1½" Long Life Wood Fastener) 1'-0" O.C. Set bottom flange of Zee closure on top of tape sealer.
4. Install Tri-Bead tape sealer to top flange of Zee closure and attach hip flash with Fastener #14A (½" x ⅜" Pop Rivet) 1'-0" O.C. **Do not attach to Panel Rib.**

DETAILS

TYPICAL DETAILS RAKE

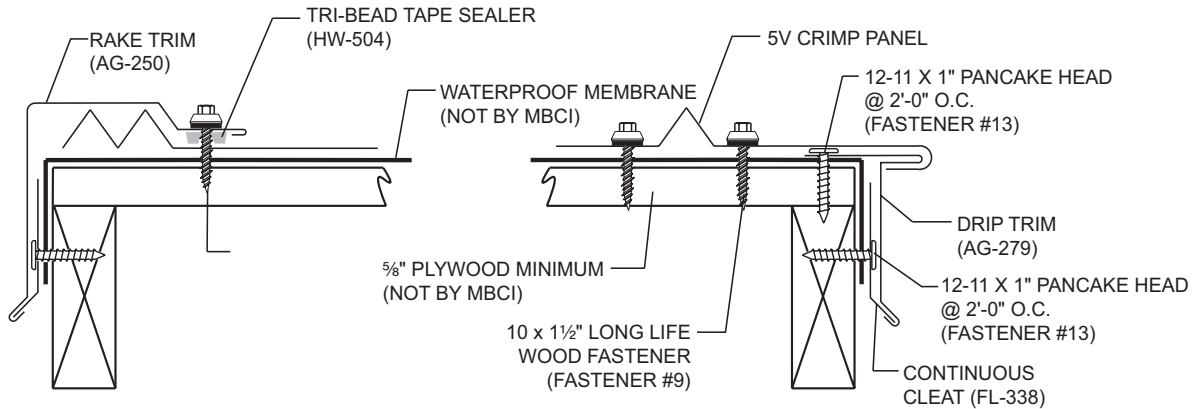

**BEGINNING/FINISHING
RAKE TRIM**

**ALTERNATE
BEGINNING/FINISHING
DRIP TRIM**

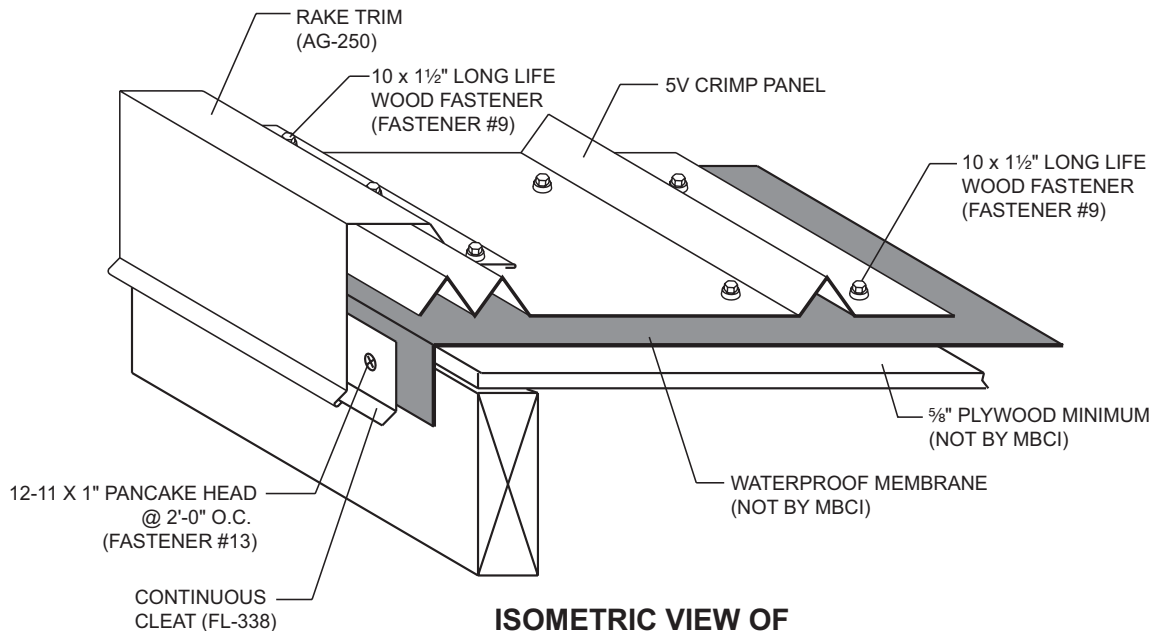

**ISOMETRIC VIEW OF
BEGINNING WITH RAKE TRIM**

NOTE:

Rake Trim

1. Install rake trim to roof panels with Fastener #9 (10 x 1½" Long Life Wood Fastener) 1'-0" O.C. Fasteners must go through Tri-Bead tape sealer.
2. When finishing off module, field bend a ½" leg up on panel before installing rake trim.

Alternate Drip Trim

1. Fasten drip trim to roof deck with Fastener #13 (10 x 1" Pancake Head) 2'-0" O.C.
2. Cut panel and bend a 1" open hem along length of panel.
3. Hook panel onto extending leg of drip trim and fasten panel to roof deck in normal manner.

DETAILS

TYPICAL DETAILS EAVE TRIM

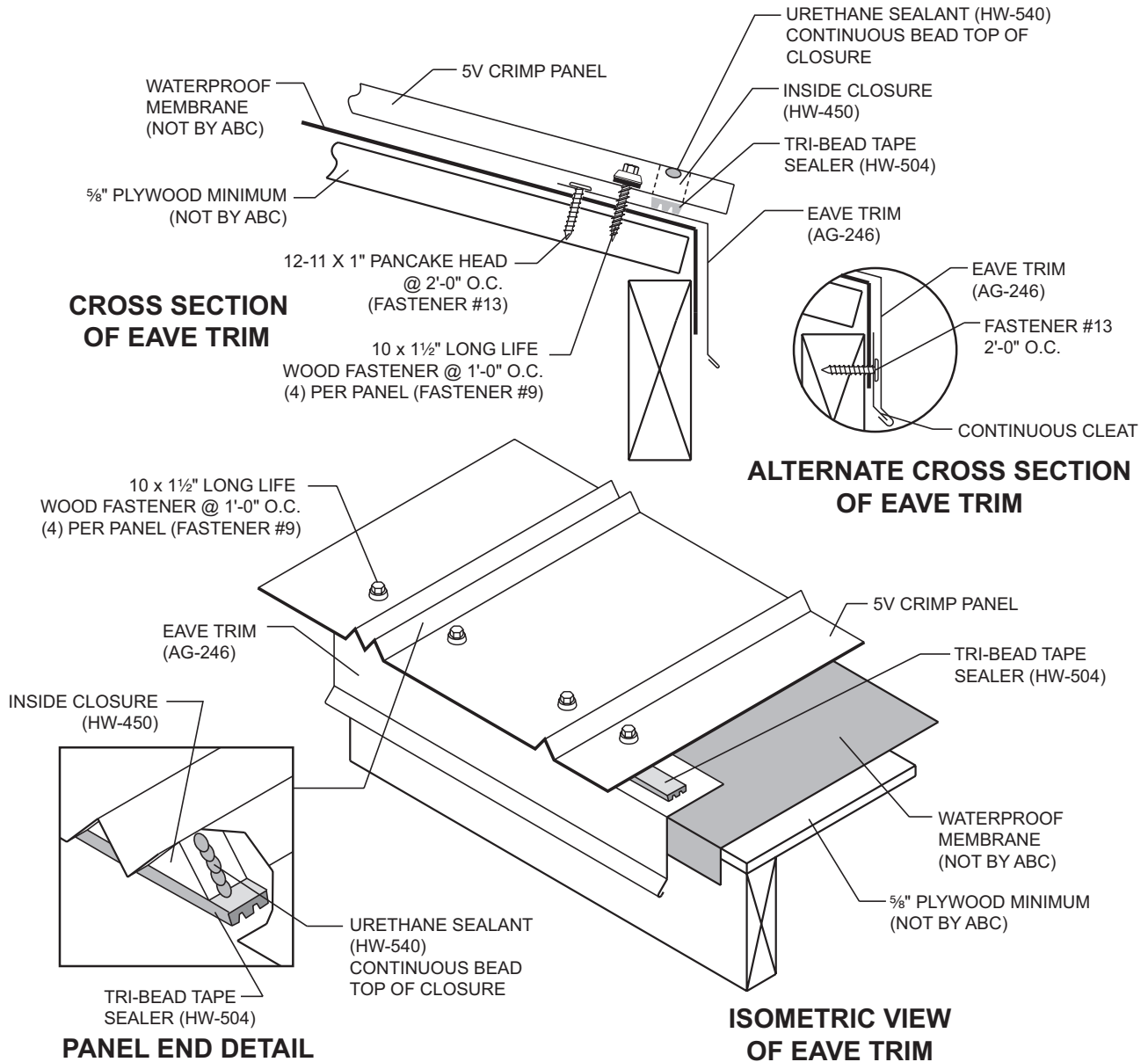

NOTE:

1. Attach eave trim to roof deck with Fastener #13 (10 x 1" Pancake Head) (2 fasteners per 10' section).
2. Install Tri-Bead tape sealer along top leg of eave trim. Install inside closure on top of Tri-Bead tape sealer. Apply a bead of urethane sealant to top of outside closure.
3. Attach panel at eave with Fastener #9 (10 x 1 1/2" Long Life Wood Fastener). Fastener pattern is shown on Page V-7.

DETAILS

TYPICAL DETAILS GUTTER

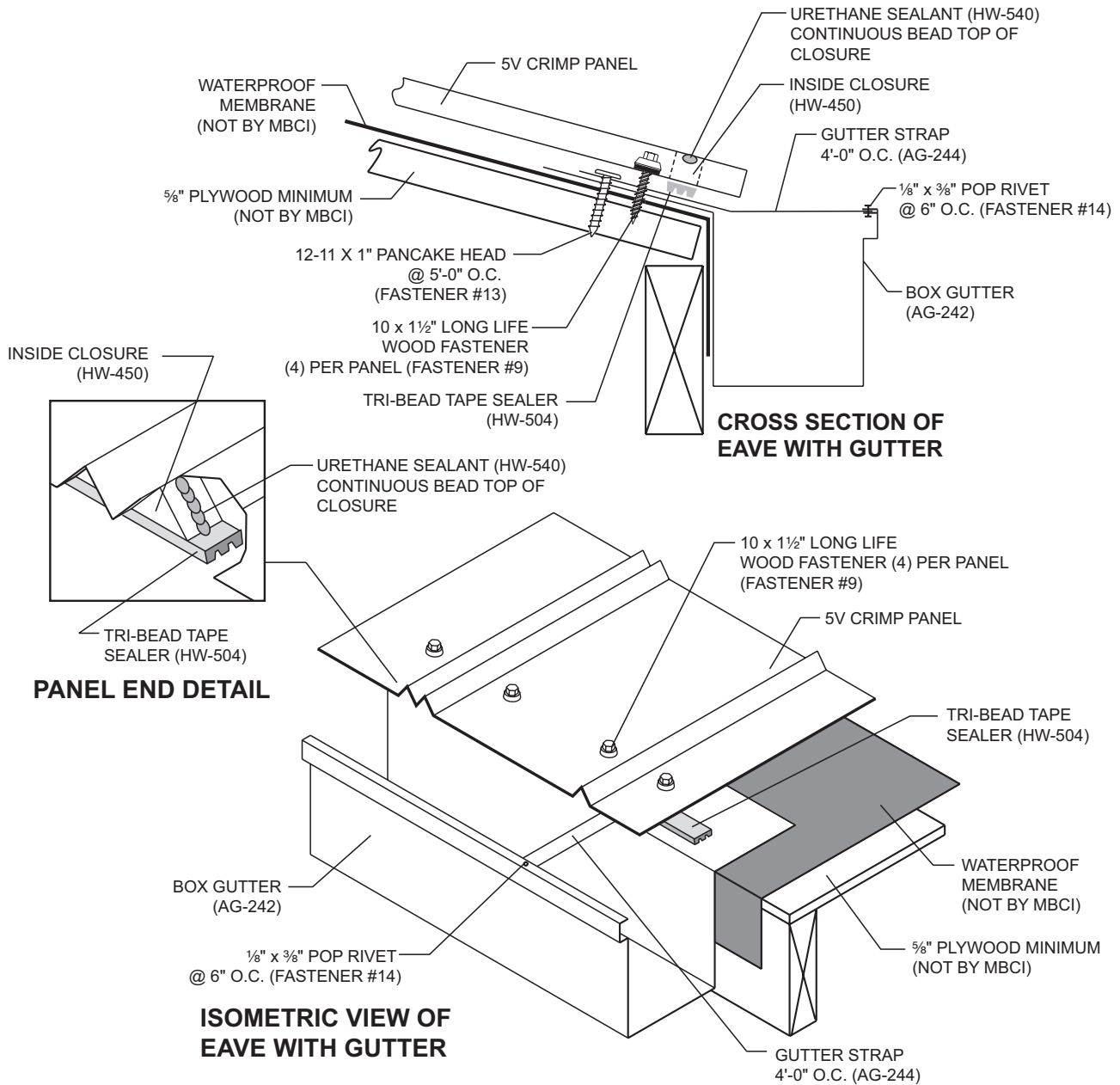

NOTE:

1. Fastener #14 (pop rivet) gutter strap to gutter 4'-0" O.C. and attach gutter to roof deck with two Fastener #13 (10 x 1" Pancake Head) per 10' section.
2. Install Tri-Bead tape sealer along top leg of gutter. Install inside closure on top of Tri-Bead tape sealer. Apply a bead of urethane sealant to top of inside closure.
3. Attach panel at eave with Fastener #9 (10 x 1 1/2" Long Life Wood Fastener). Fastener pattern is shown on Page V-7.

DETAILS

TYPICAL DETAILS SLOPE CHANGE

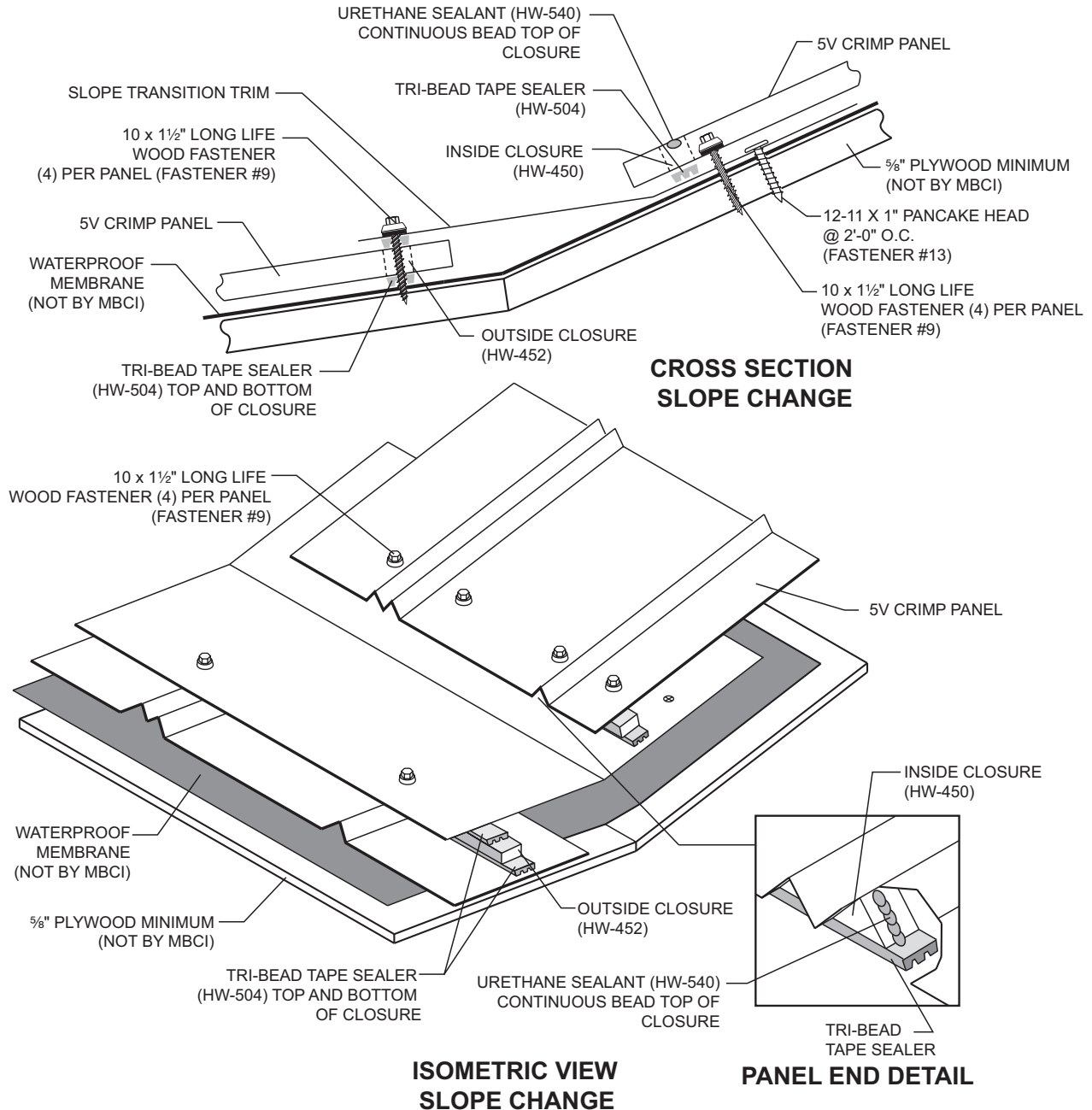

NOTE:

1. Install eave panel with Fastener #9 (10 x 1 1/2" Long Life Wood Fastener). Apply Tri-Bead tape sealant on the bottom and top of the outside closure that is mounted down hill from the end of panel.
2. Install transition trim on top of the outside closure with hem of the trim being 1 inch from Fastener #9 (10 x 1 1/2" Long Life Wood Fastener) that is located 1'-0" O.C. and placed in the high part of the rib.
3. Fasten down top of trim with two Fasteners #13 (10 x 1" pancake head) per 10'-0" section of trim. Place Tri-Bead tape sealant on top of trim prior to placement of inside closure. Closure should be 1" from end of panel.
4. Apply a large bead of urethane sealant to top of the inside closure prior to placing panel on top of closure.
5. Attach uphill panel with Fastener #9 (10 x 1 1/2" Long Life Wood Fastener). Fastener pattern is shown on Page V-7.



NOTES

NOTES



Metal Roof and Wall Systems

For the most current information available, visit our Web site at www.mbc.com

Houston, TX
14031 West Hardy
P.O. Box 38217
Houston, TX 77238
281-407-6915

Adel, GA
1601 Rogers Road
P.O. Box 1107
Adel, GA 31620
888-514-6062

Atlanta, GA
2280 Monier Avenue
P.O. Box 44729
Atlanta, GA 30336
678-337-1619

Atwater, CA
550 Industry Way
P.O. Box 793
Atwater, CA 95301
209-445-3891

Indianapolis, IN
1780 McCall Drive
P.O. Box 657
Shelbyville, IN 46176
317-364-4329

Lubbock, TX
5711 East FM-40
P.O. Box 10133
Lubbock, TX 79408
806-224-2724

Memphis, TN
300 Highway 51 North
P.O. Box 366
Hernando, MS 38632
662-298-2337

Oklahoma City, OK
7000 S. Eastern Avenue
P.O. Box 95998
Oklahoma City, OK 73149
405-492-6968

Omaha, NE
1011 Ellison Avenue
Omaha, NE 68110
402-983-8006

Phoenix, AZ
660 South 91st Avenue
P.O. Box 739
Tolleson, AZ 85353
480-630-3022

Rome, NY
6168 State Route 233
P.O. Box 4141
Rome, NY 13442
315-371-4330

Salt Lake City, UT
1155 West 2300 North
P.O. Box 16027
Salt Lake City, UT 84116
385-715-2952

San Antonio, TX
8677 I-10 East
P.O. Box 69
Converse, TX 78109
210-888-9768

